

8 • CHARTING TAXONOMY

Data Visualization and Visual Analytics

TEACHER

Salvatore Rinzivillo

University of Pisa

Department of Computer Science

Course: Visual Analytics

Academic Year: 2026

Crash Course on Effective Charting

THE WALL STREET JOURNAL.
**GUIDE TO
INFORMATION
GRAPHICS**
**THE DOS & DON'TS
OF PRESENTING
DATA, FACTS,
AND FIGURES**

Dona M. Wong

Guide to Information Graphics

The Dos and Don'ts of Presenting Data, Facts, and
Figures • W. W. Norton & Company

Charting Examples

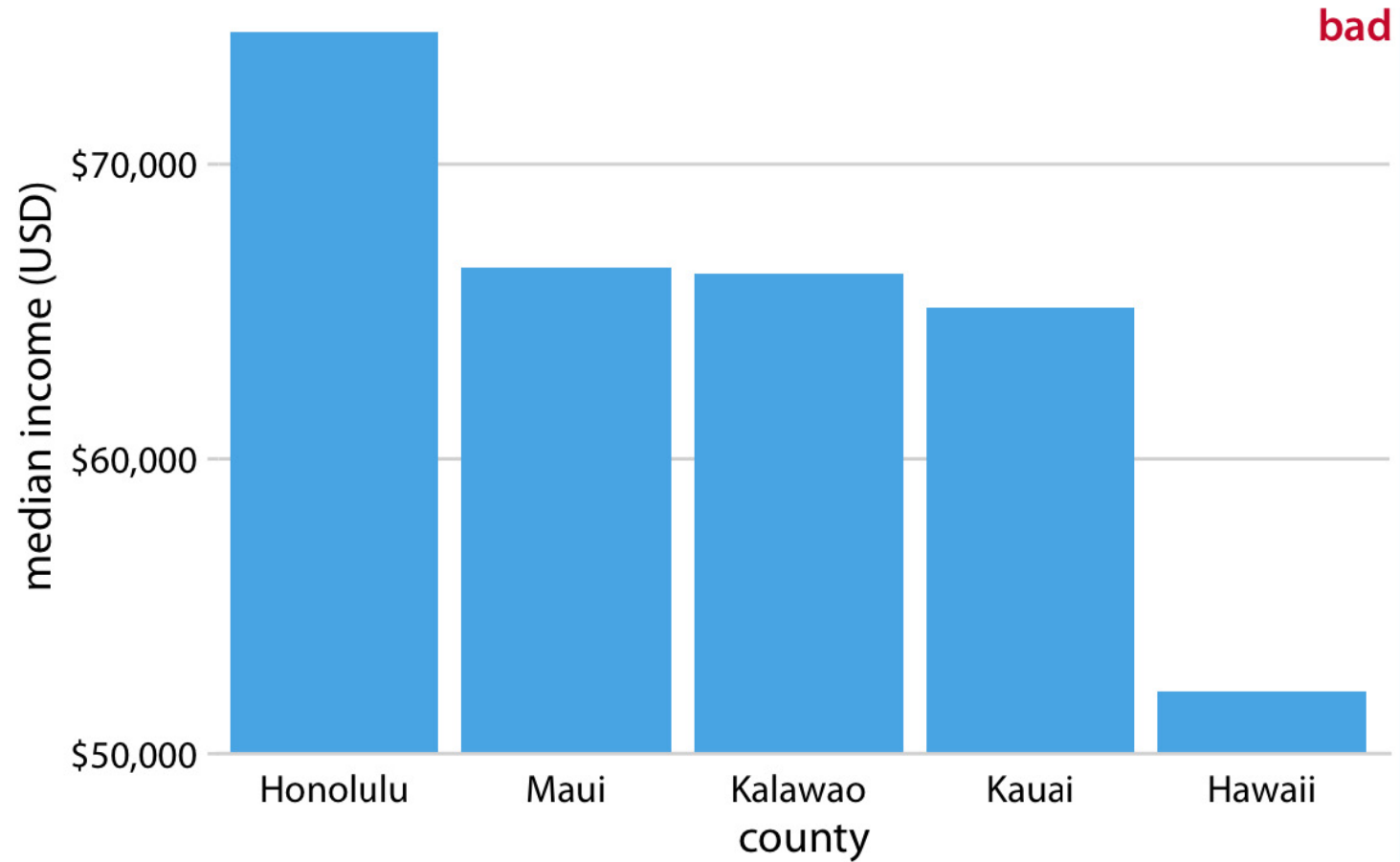

Charting Examples

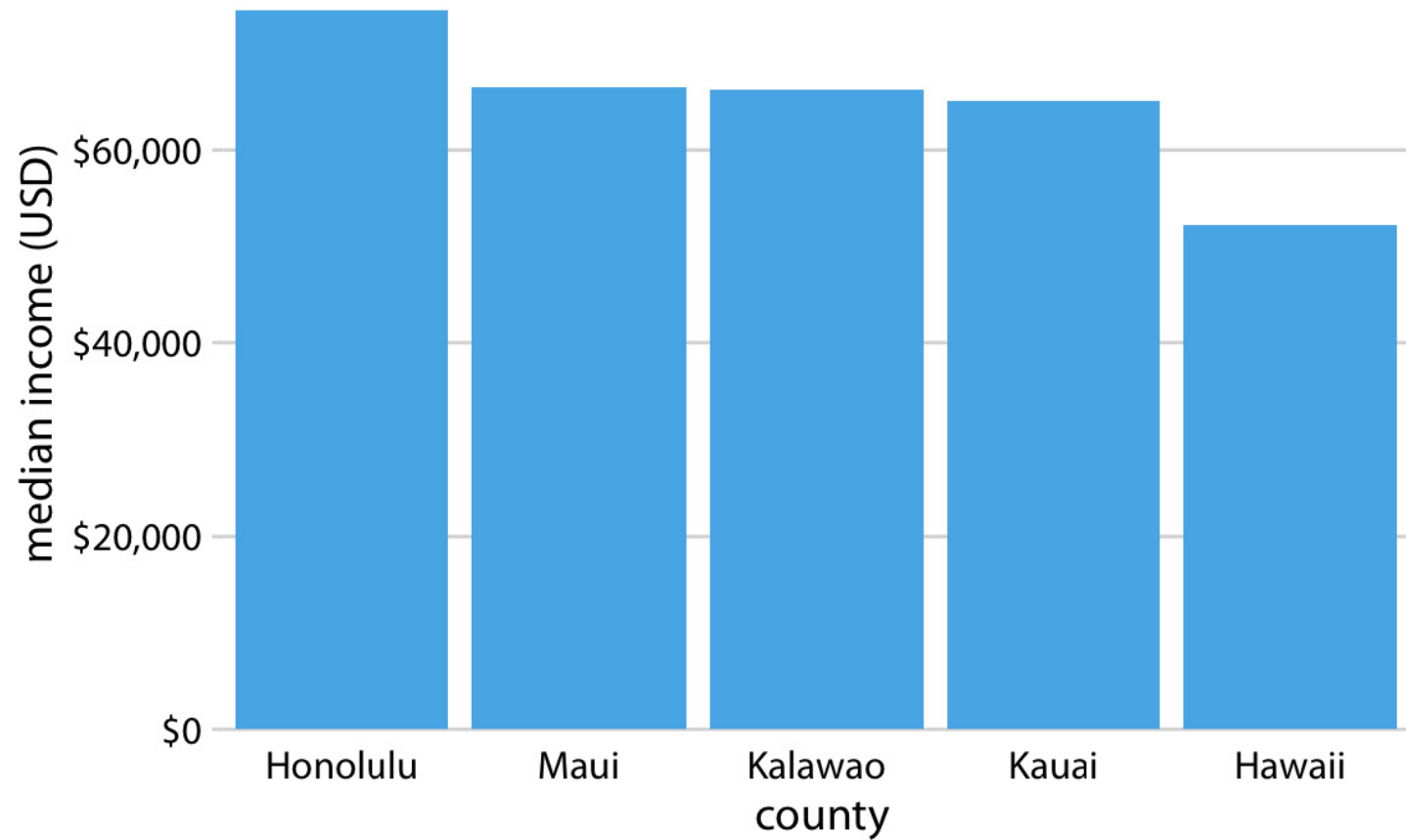

Charting Examples

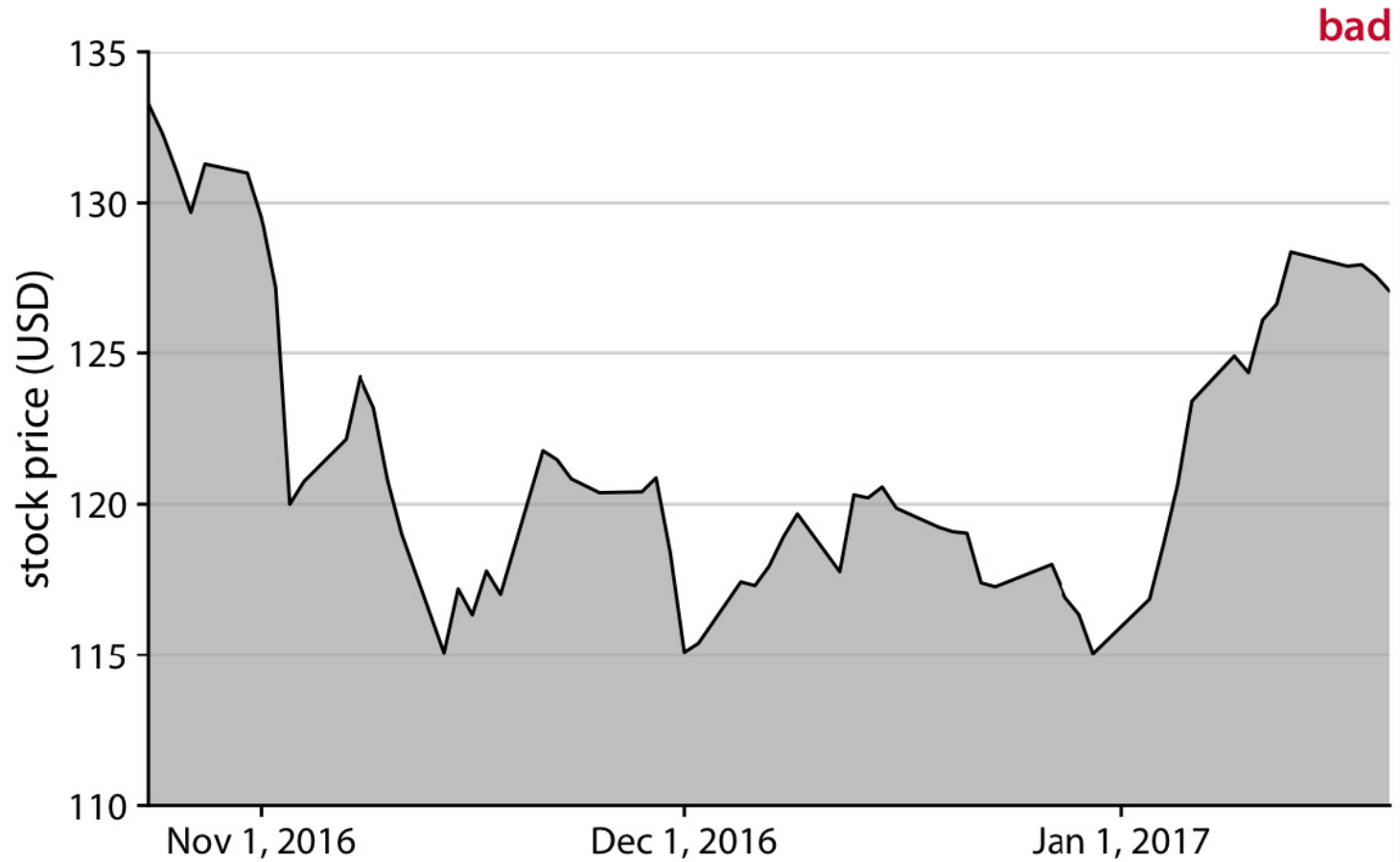

Charting Examples

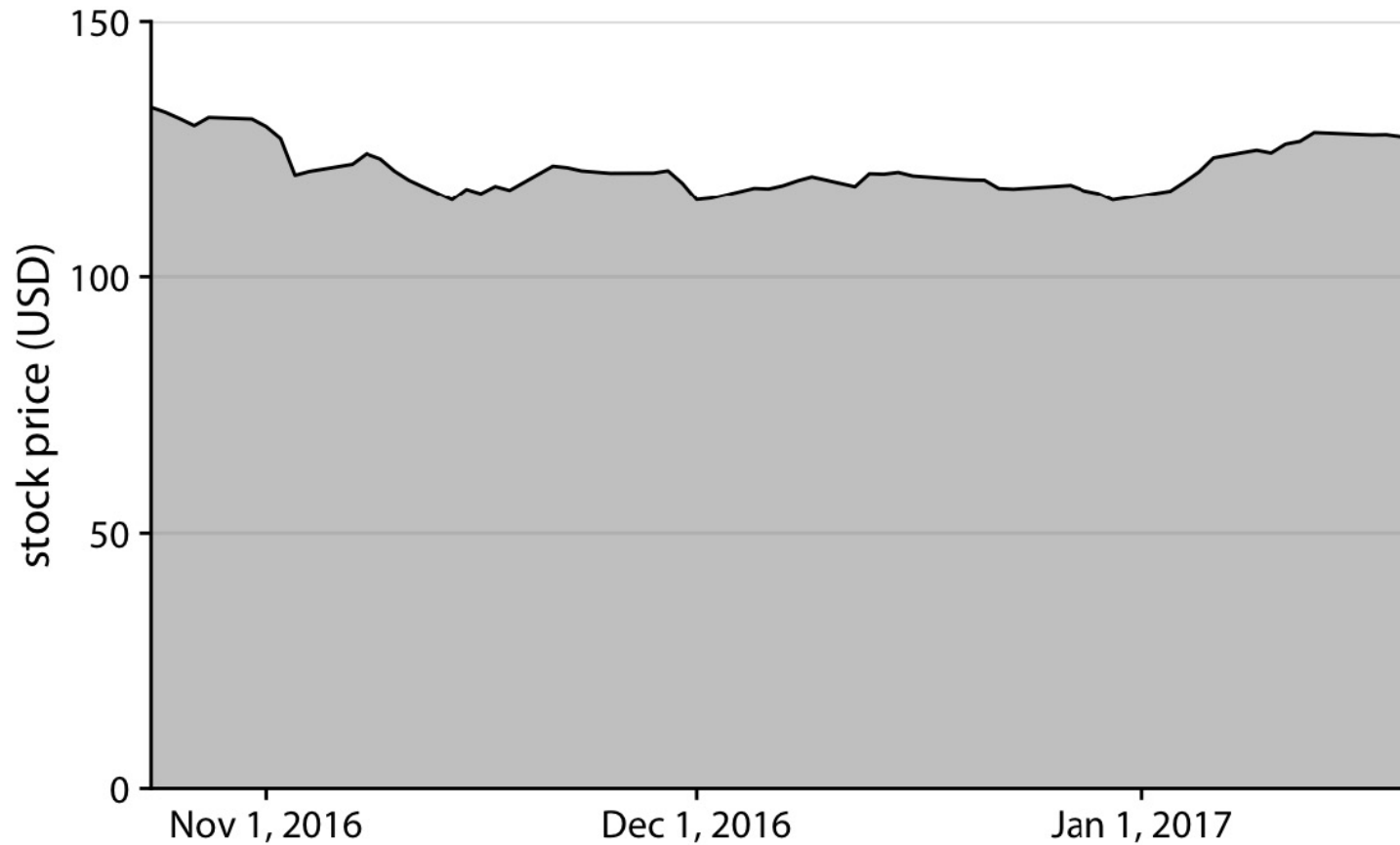

Charting Examples

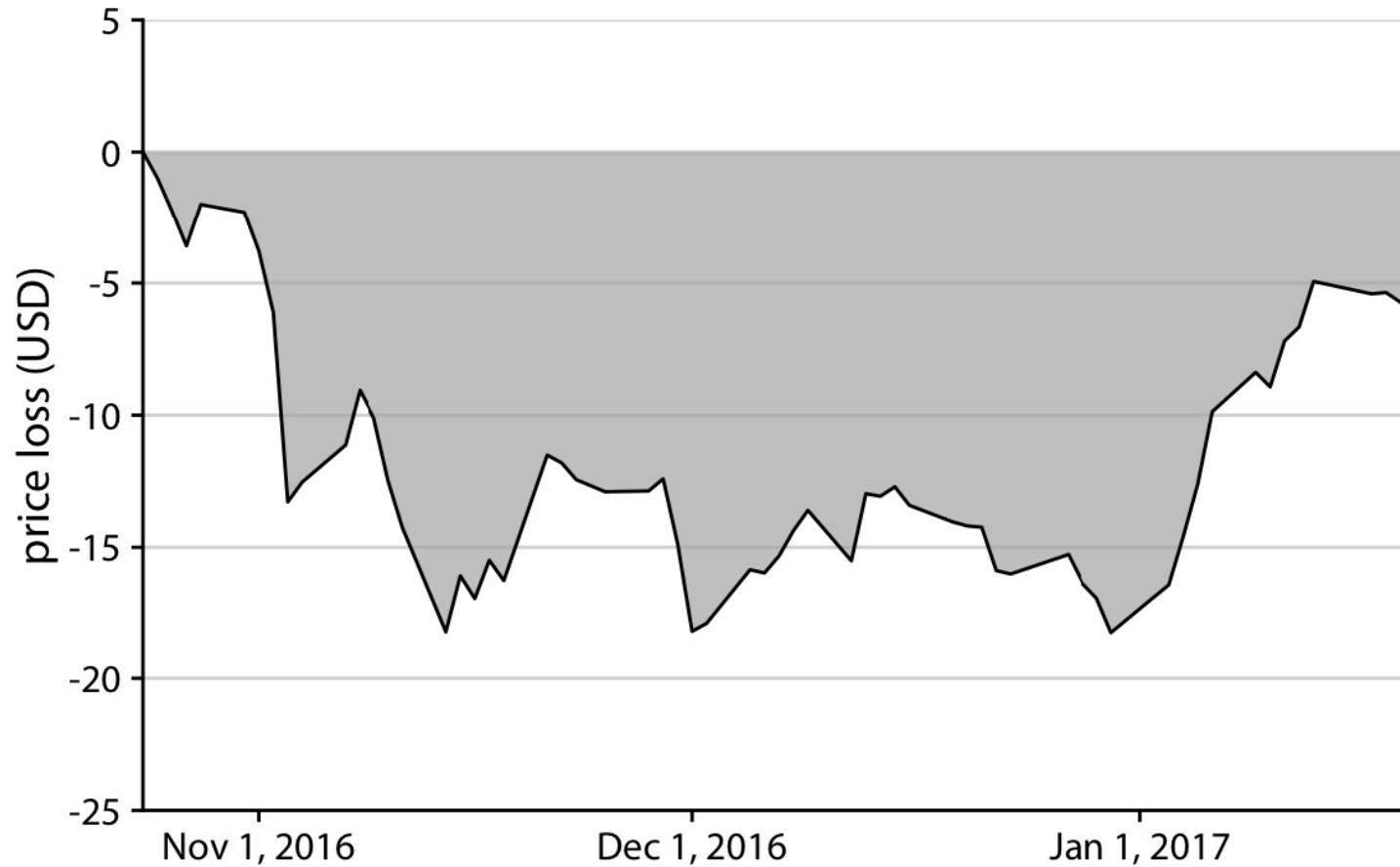

Charting Examples

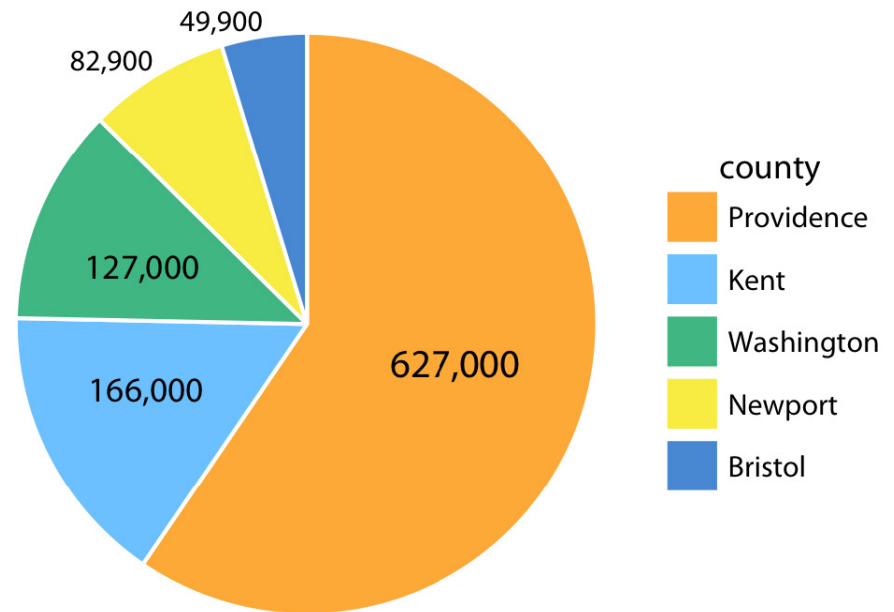
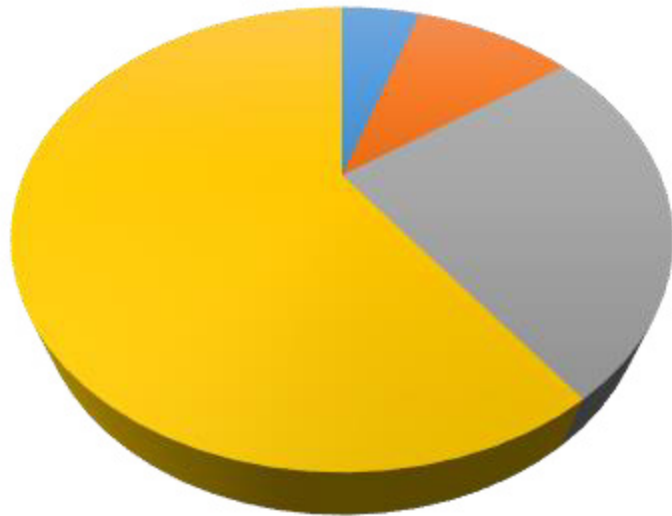

May these charts be improved? Why? How?

Charting Examples

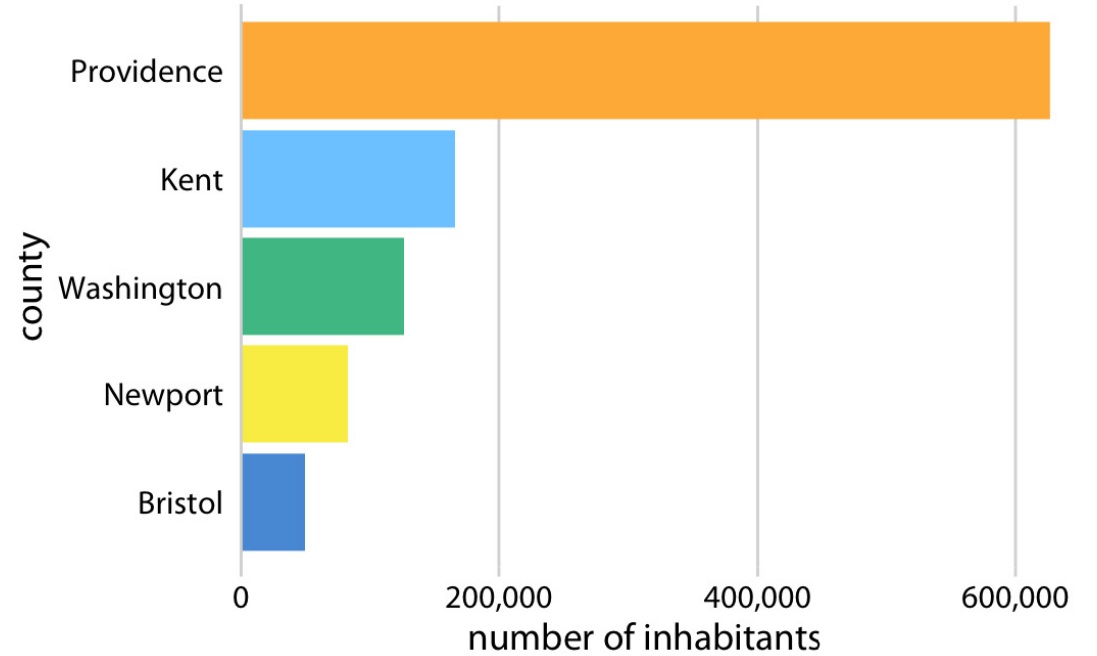
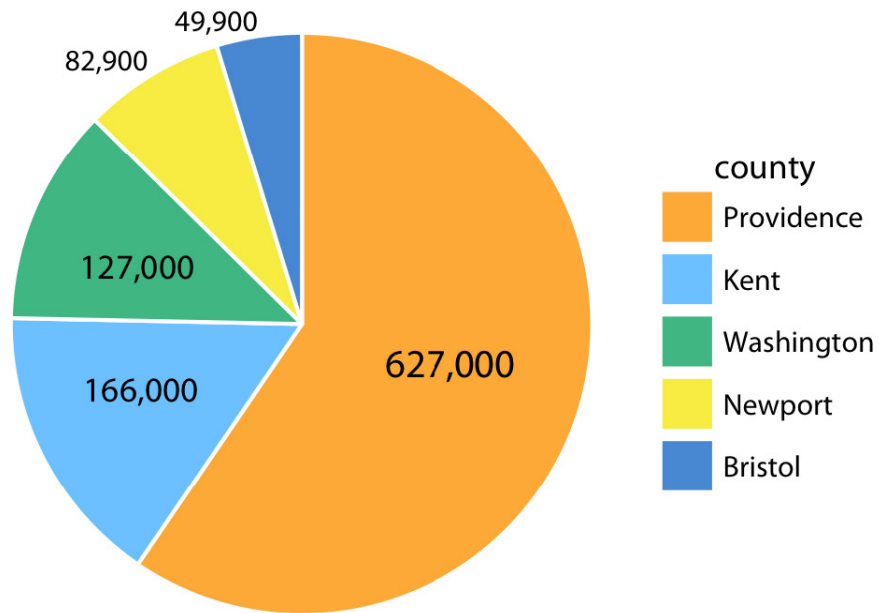

FONTS



Font Anatomy

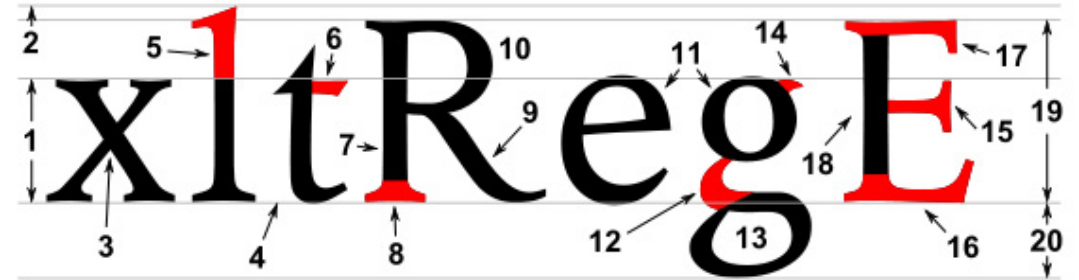
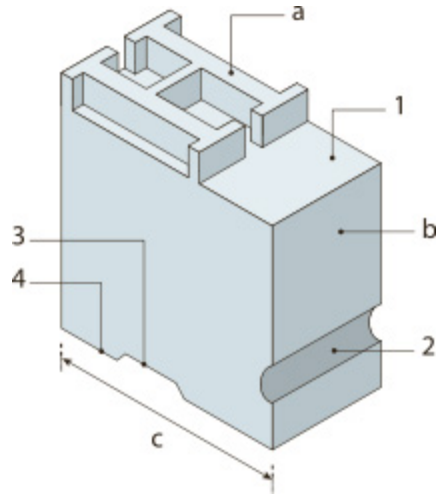

Typographic parts of a glyph: 1) x-height; **2) ascender line; **3) apex; **4) baseline; **5) ascender; 6) crossbar; 7) stem; **8) serif; **9) leg; 10) bowl; 11) counter; 12) collar; 13) loop; 14) ear; 15) tie; 16) horizontal bar; 17) arm; 18) vertical bar; 19) cap height; **20) descenderline.**

Font size = (1) + (2) + (20) = (19) + (20)

General Rules

- Leading should be 2 points larger than type size
- Avoid too small or condensed type faces
- Keep style simple: use bold or italic to emphasize a word (better not both)
- Avoid ALL CAPS
- Avoid styled fonts
- Avoid C***C Sans
- Reduce type at an angle
- Avoid t r a c k i n g

Fonts are meant to describe not to adorn

Typography in Charts

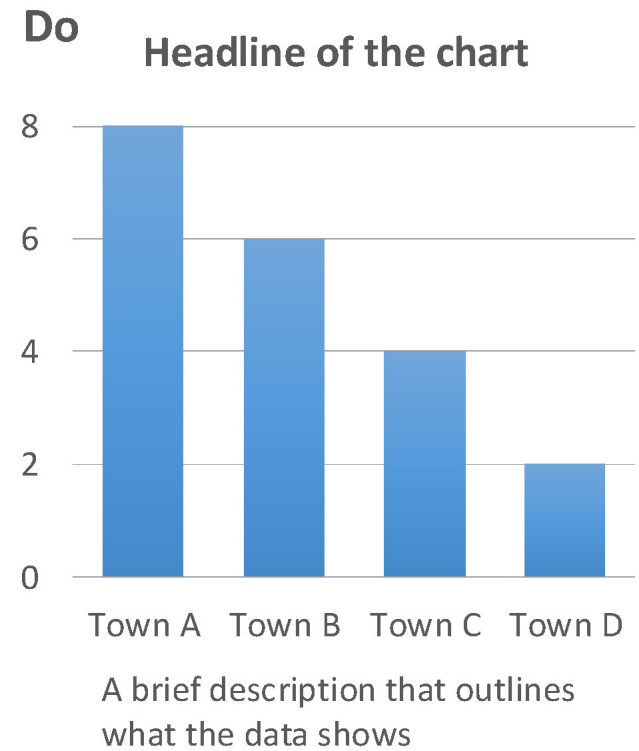
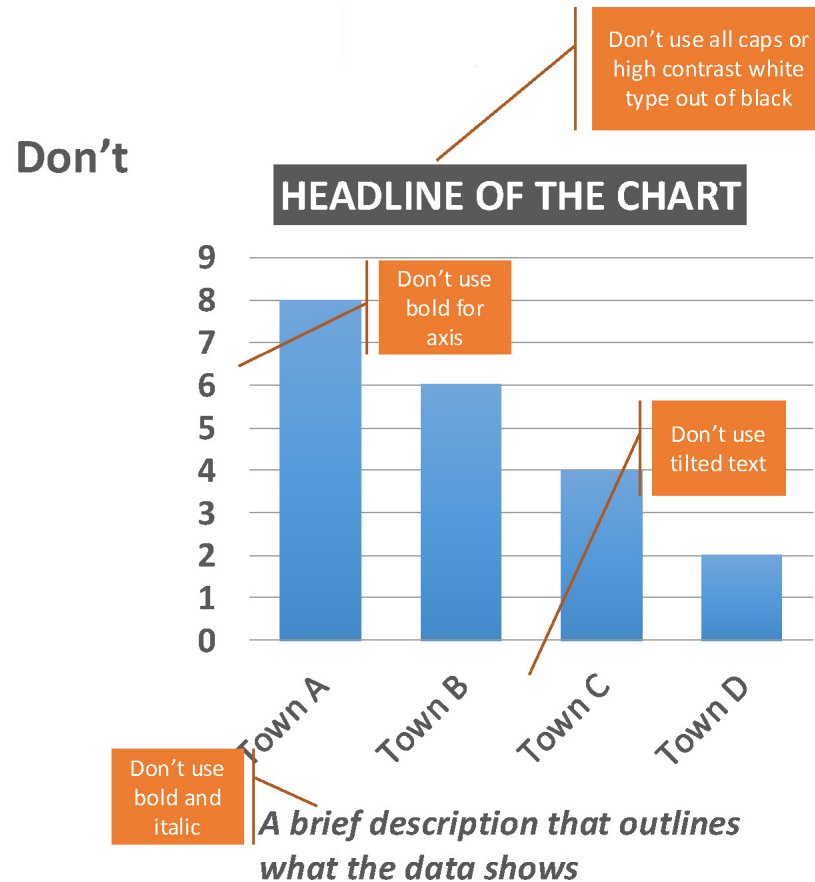

Typography in Charts

Headline of the chart

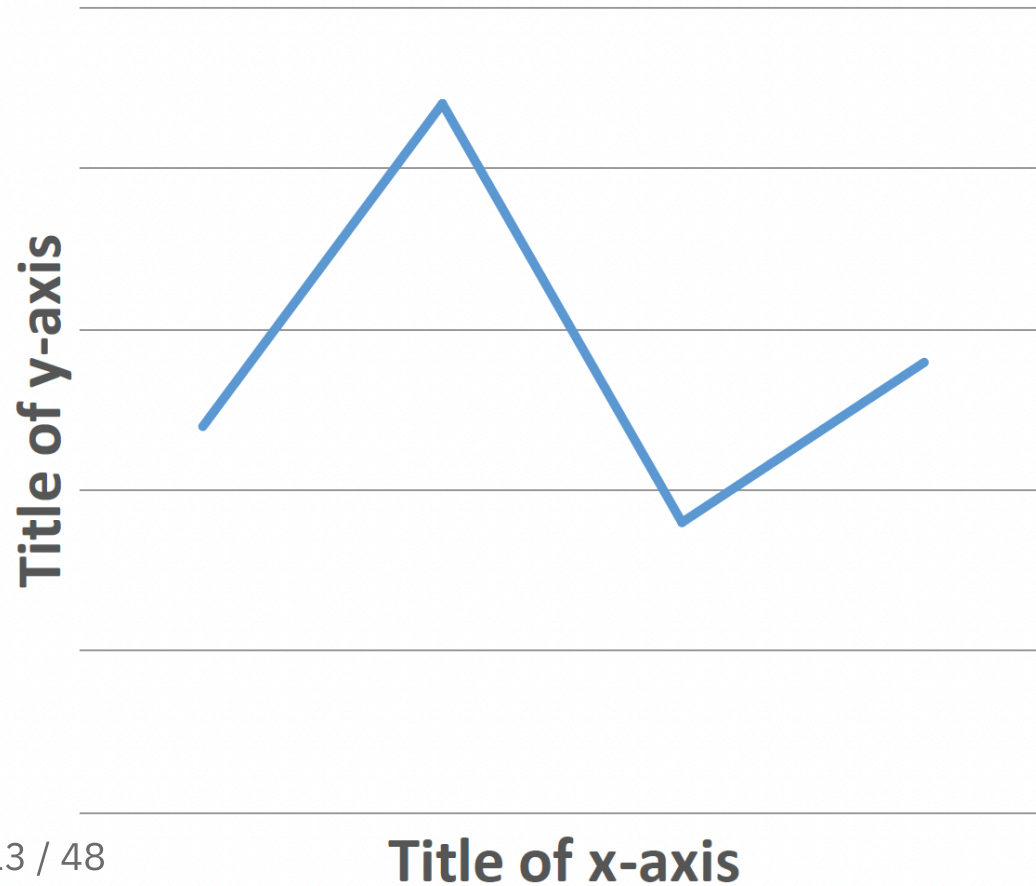

Headline of the chart

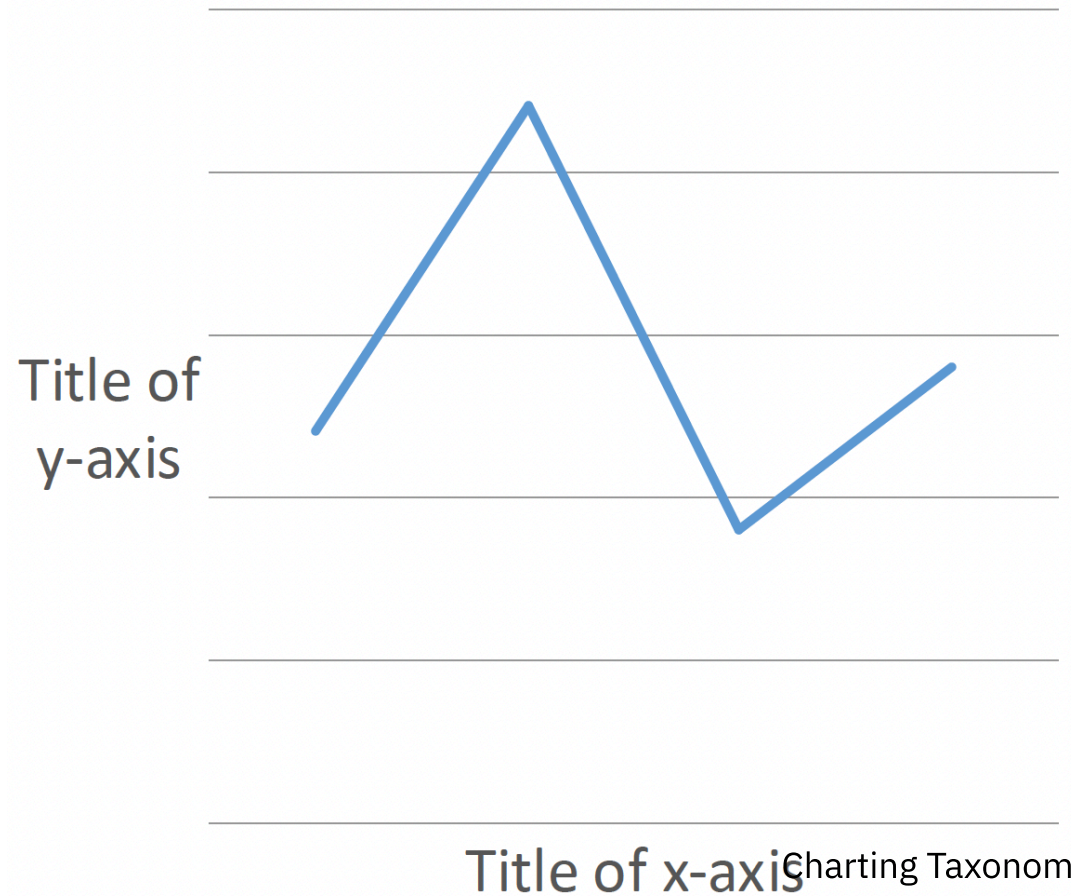

Typography in Charts

Don't

Name	Data	Data	Data
Company A	0.0	0.0	0.0
Company B	0.0	0.0	0.0
Company C	0.0	0.0	0.0
Company D	0.0	0.0	0.0

Many elements in bold.
Which part is highlighted?

Do

Name	Data	Data	Data
Company A	0.0	0.0	0.0
Company B	0.0	0.0	0.0
Company C	0.0	0.0	0.0
Company D	0.0	0.0	0.0

Give emphasis to relevant results

DATA-INK RATIO

Visual Display of Quantitative Data

Edward Tufte, 1983

Data-Ink Ratio

$$\text{Data-Ink Ratio} = \frac{\text{Data ink}}{\text{Total ink used in graphic}}$$

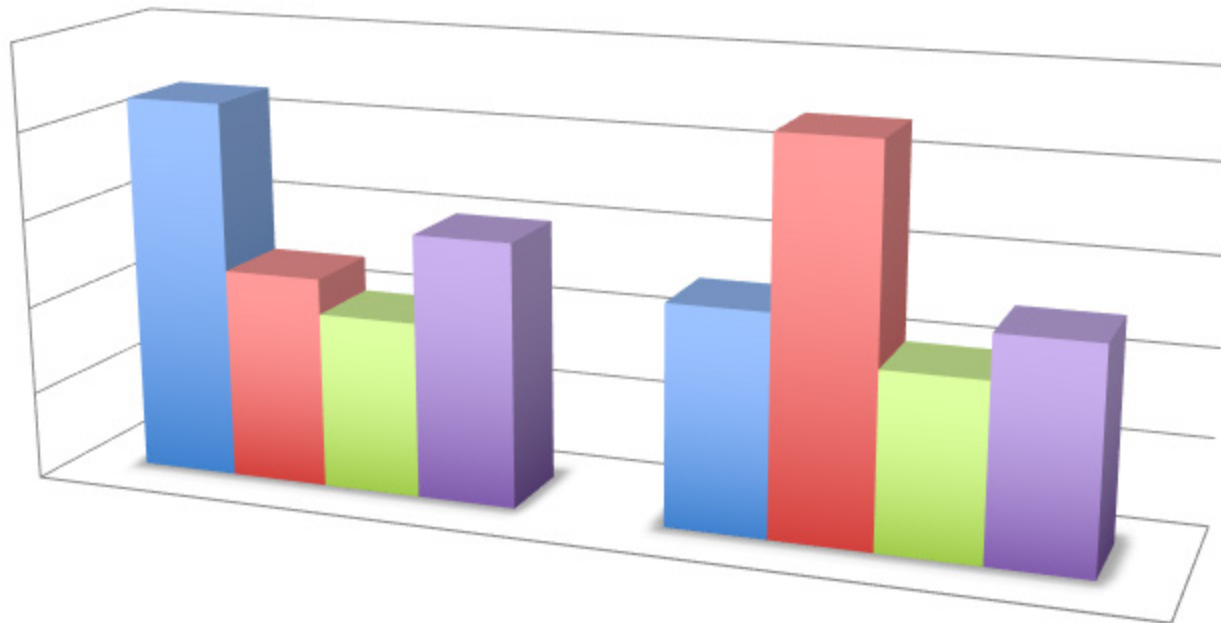

Data-Ink Ratio

$$\text{Data-Ink Ratio} = \frac{\text{Data ink}}{\text{Total ink used in graphic}}$$

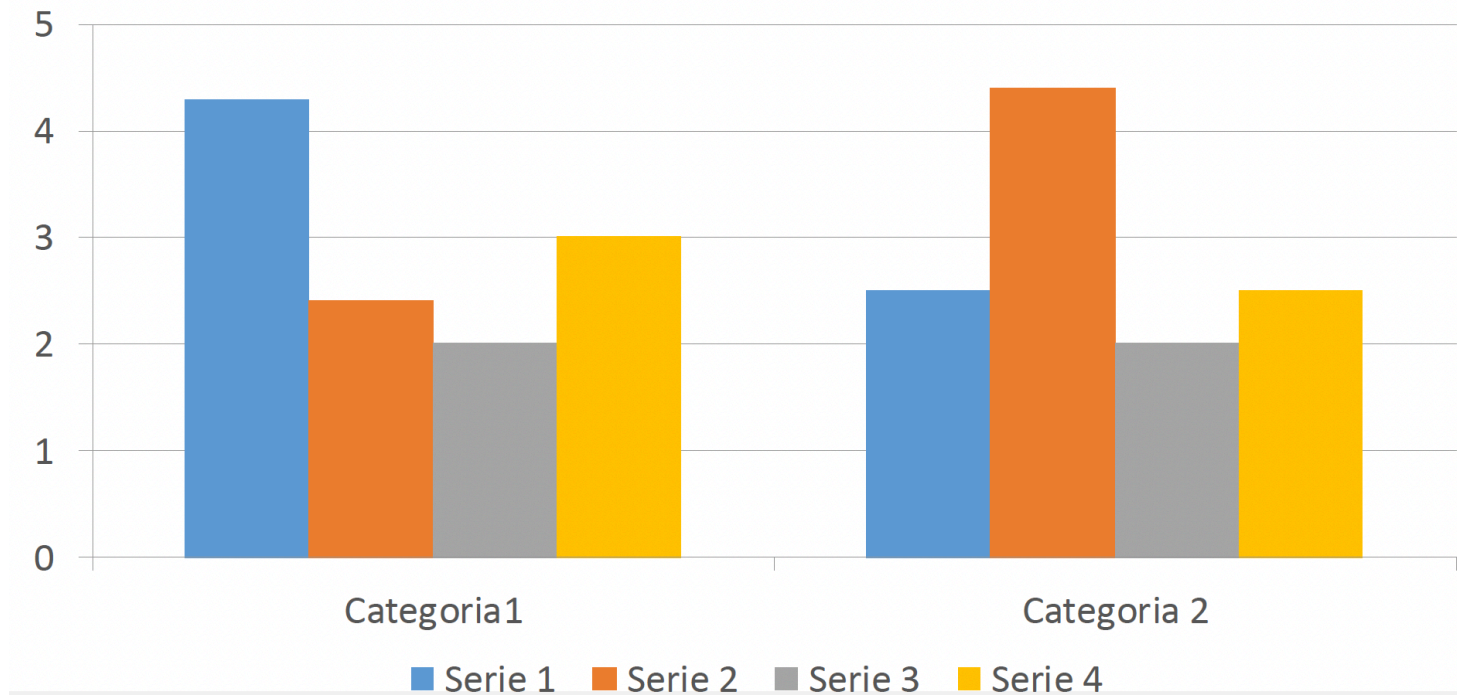

Bar Charts

Represent discrete quantities

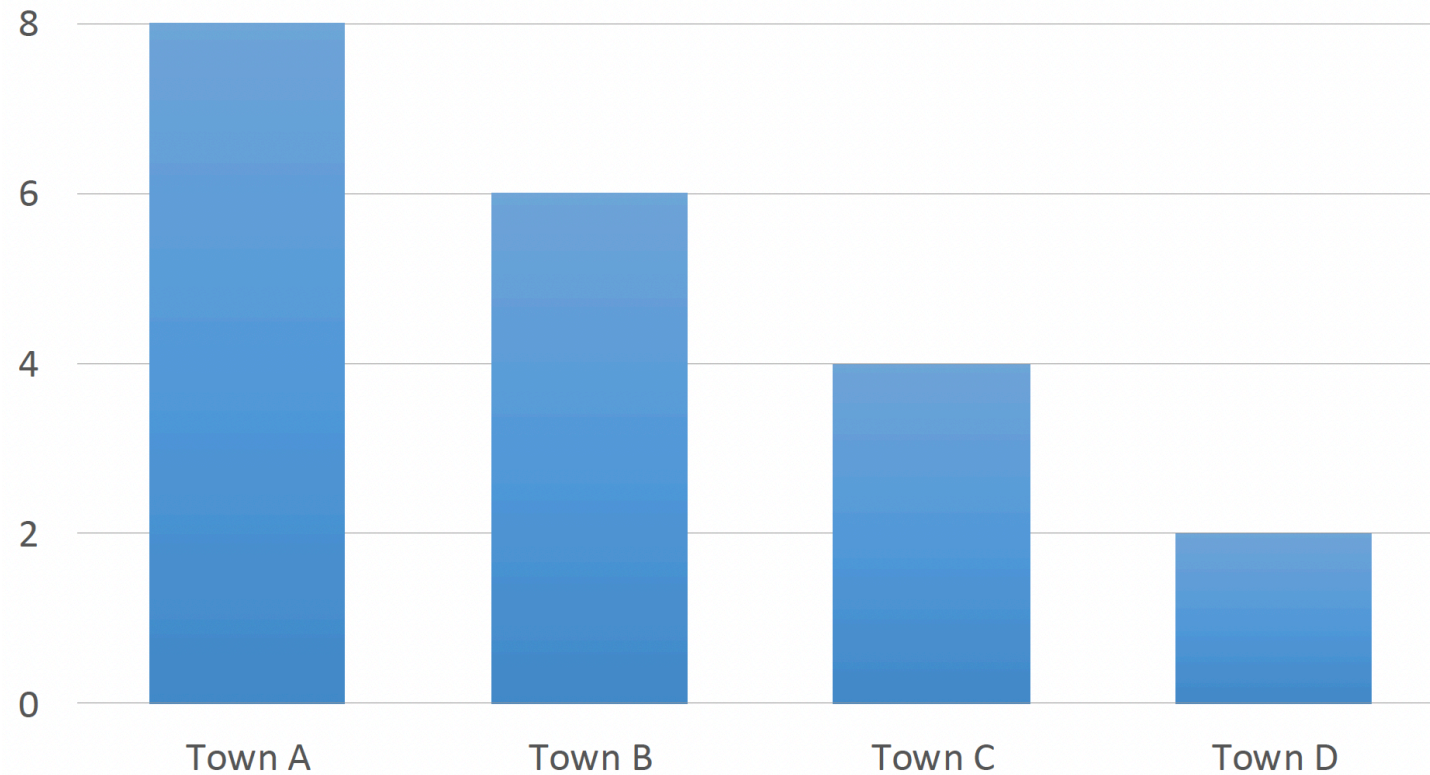

Bar Charts

Avoid non-functional adoration

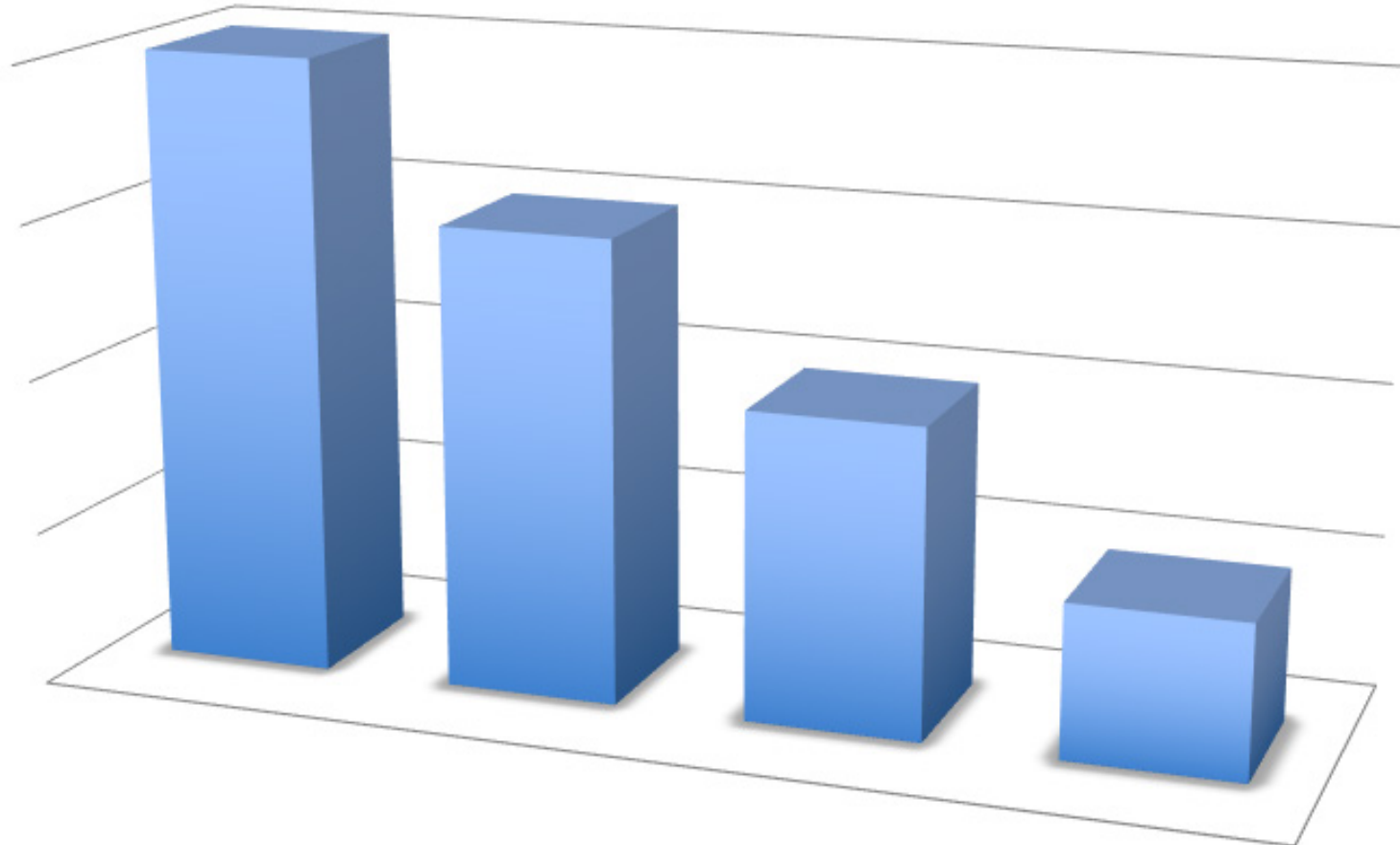

Bar Charts: Baseline

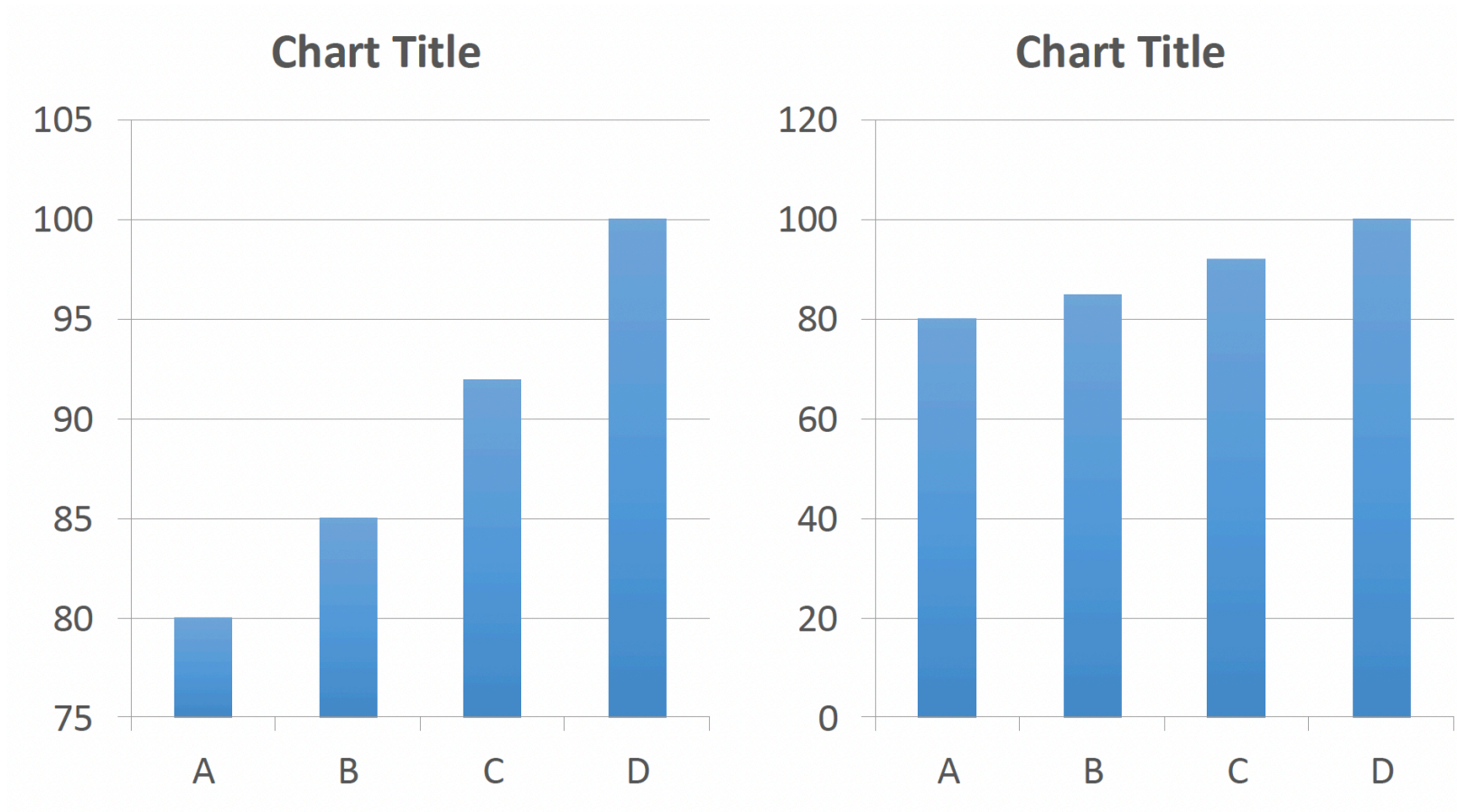

Bar Charts: Baseline

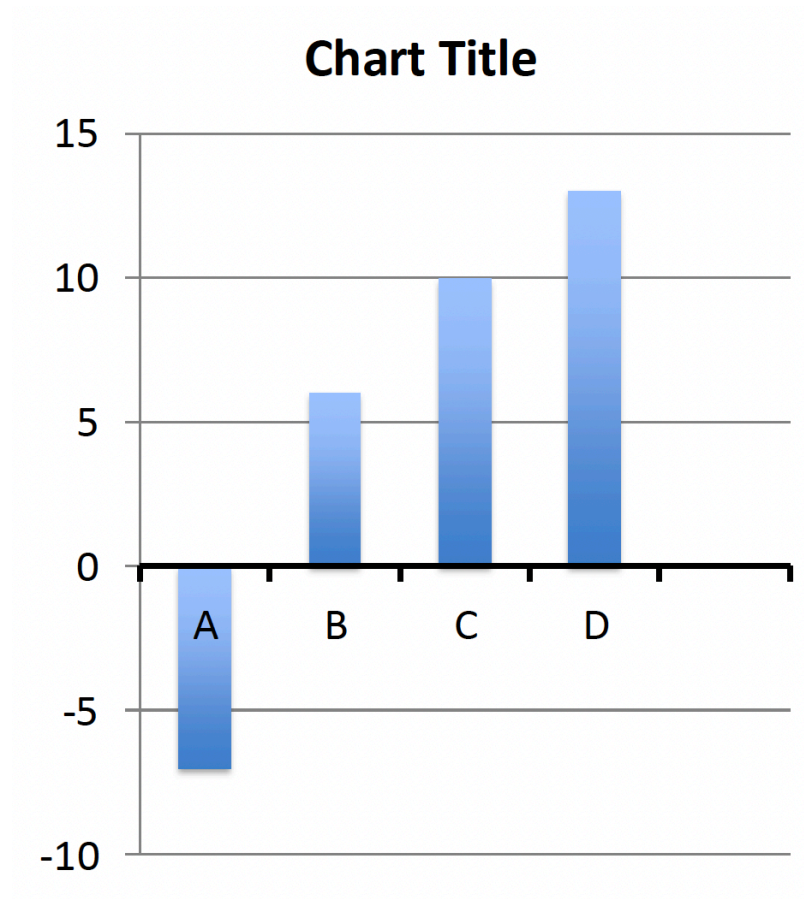

Bar Charts: Ordering

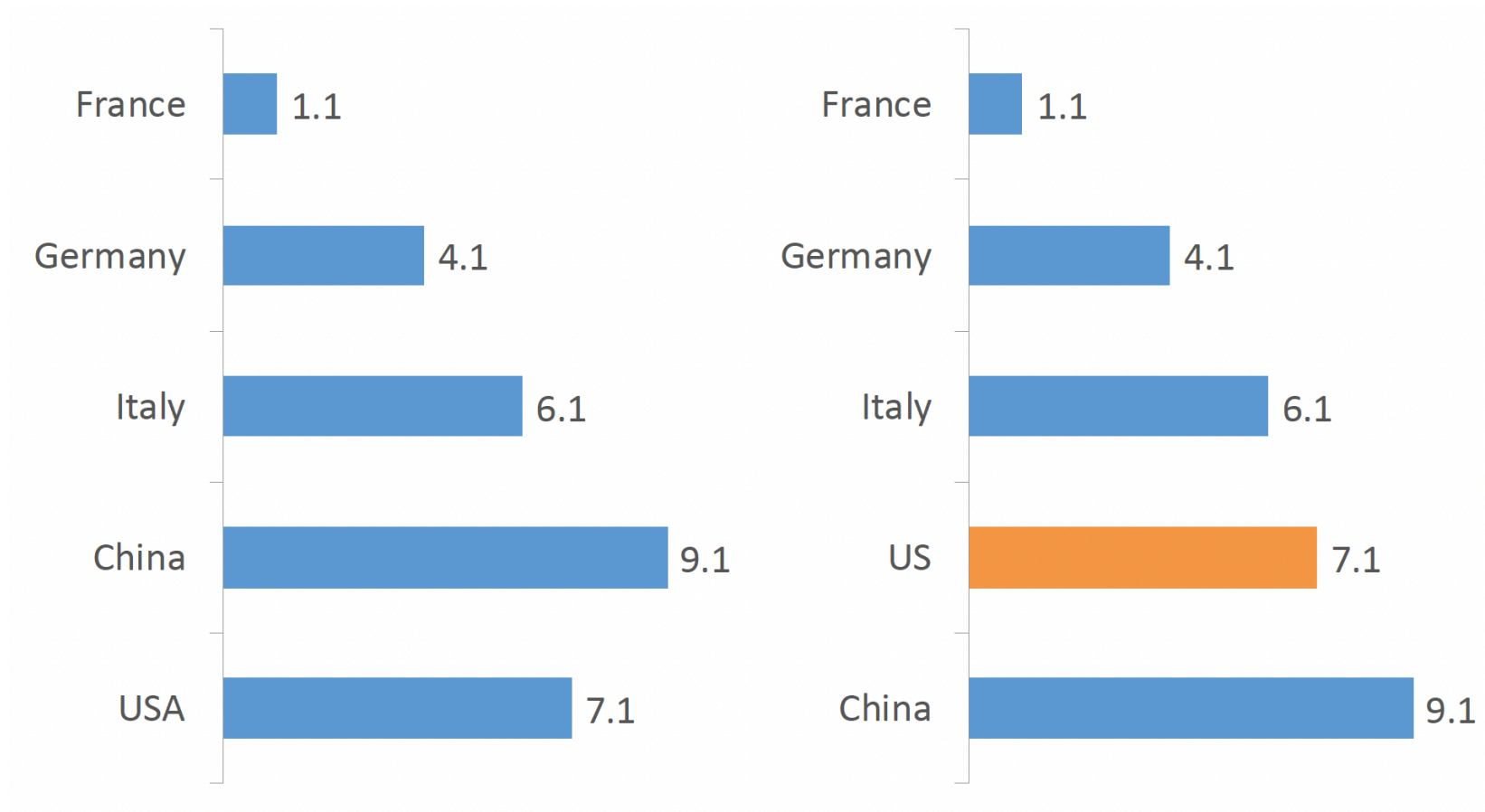

Pie Charts

- Pie Charts compare relative sizes and contributions

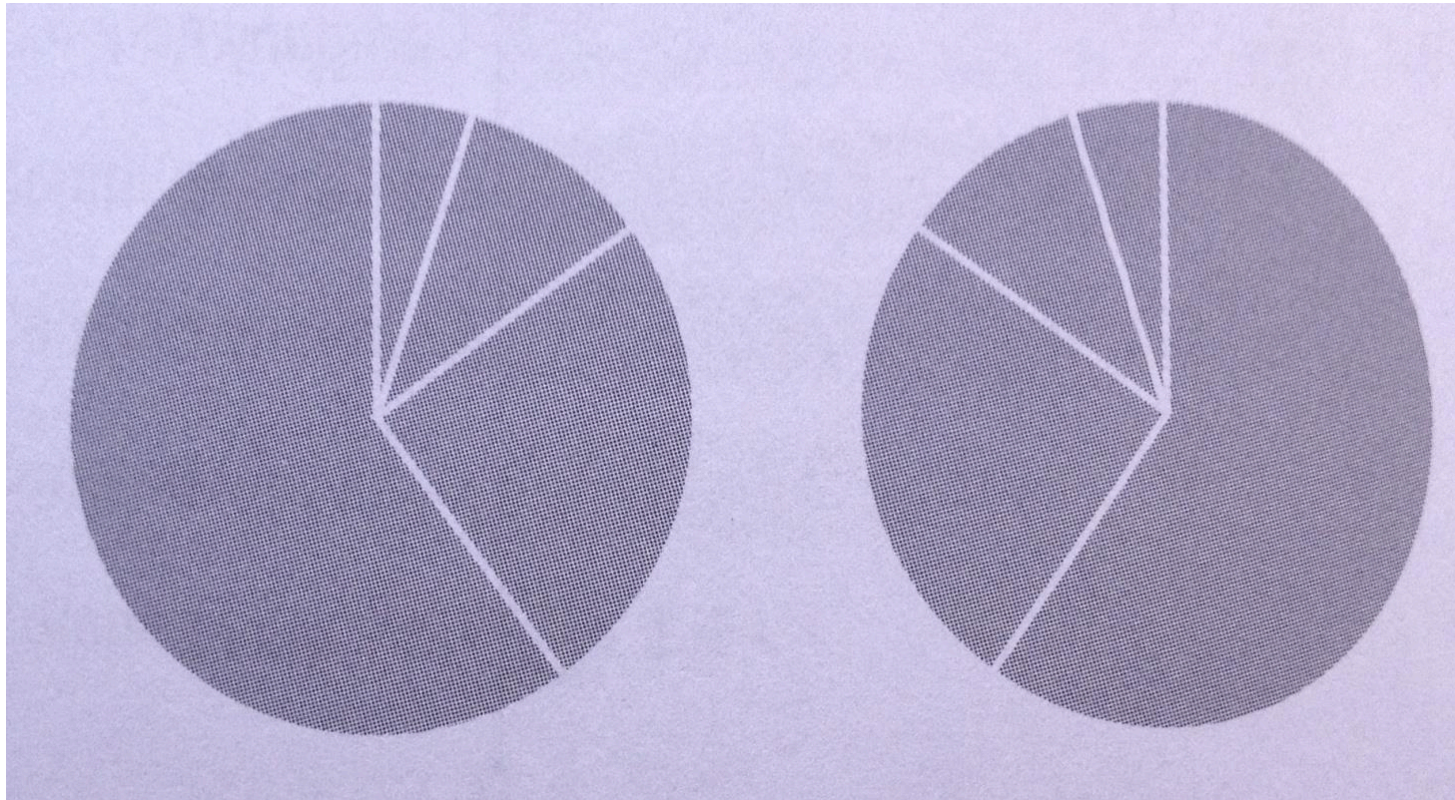

Pie Charts: Ordering Slices

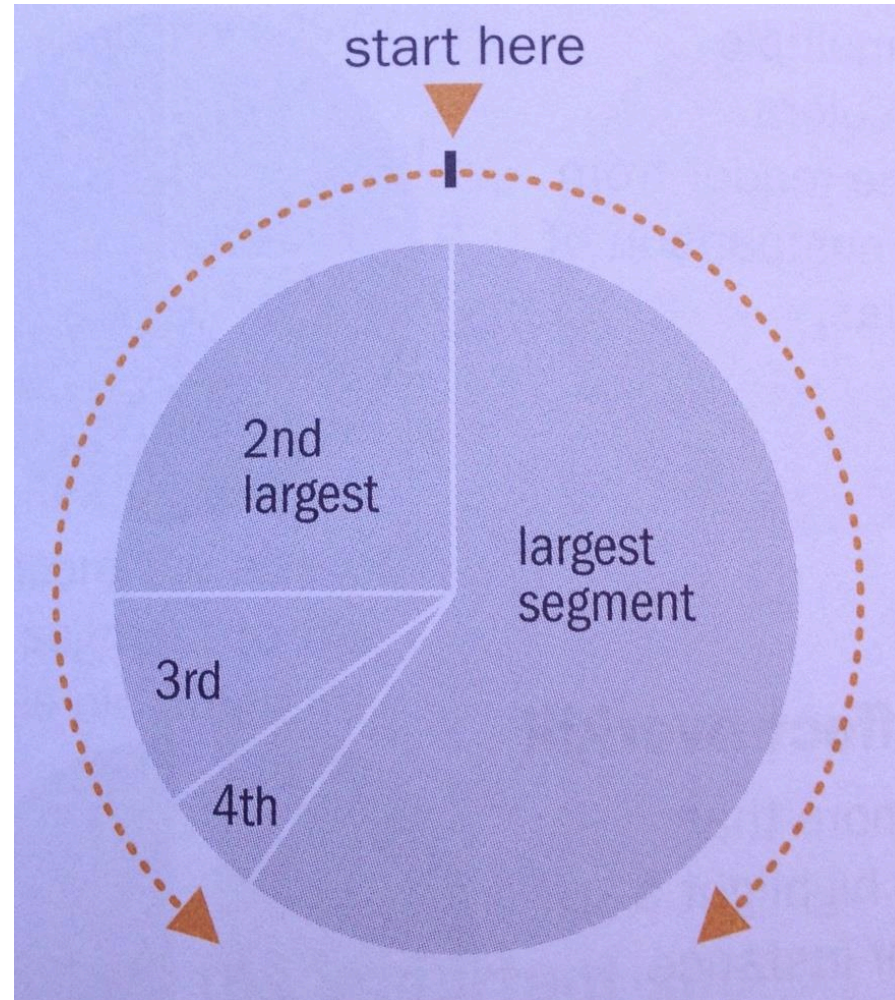

Pie vs Bar Charts

65% of the market is controlled by companies B and C

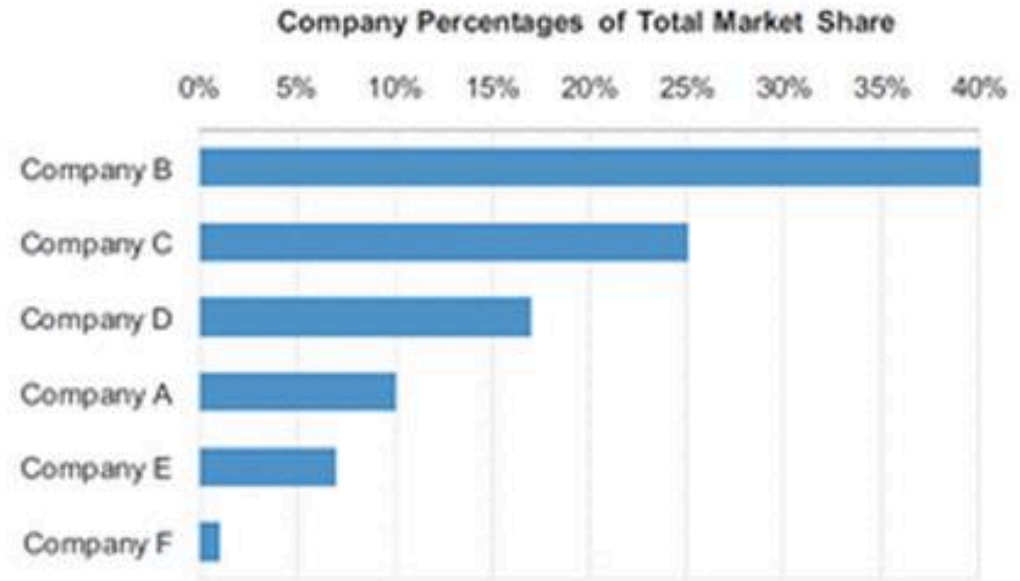
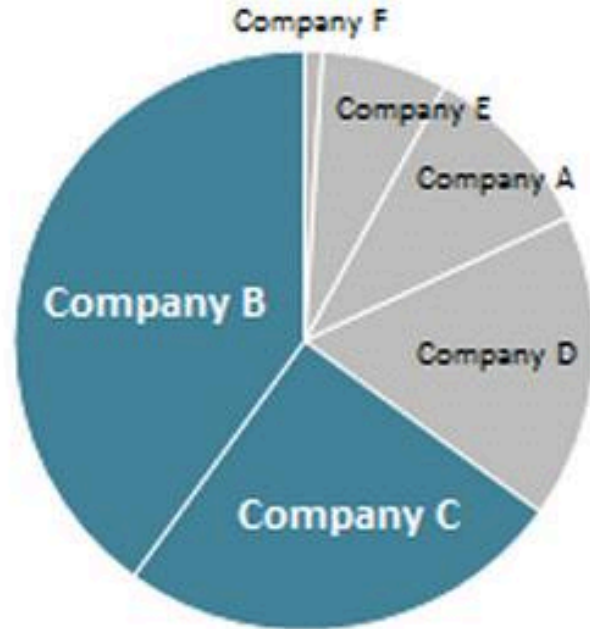

Visualization Taxonomy

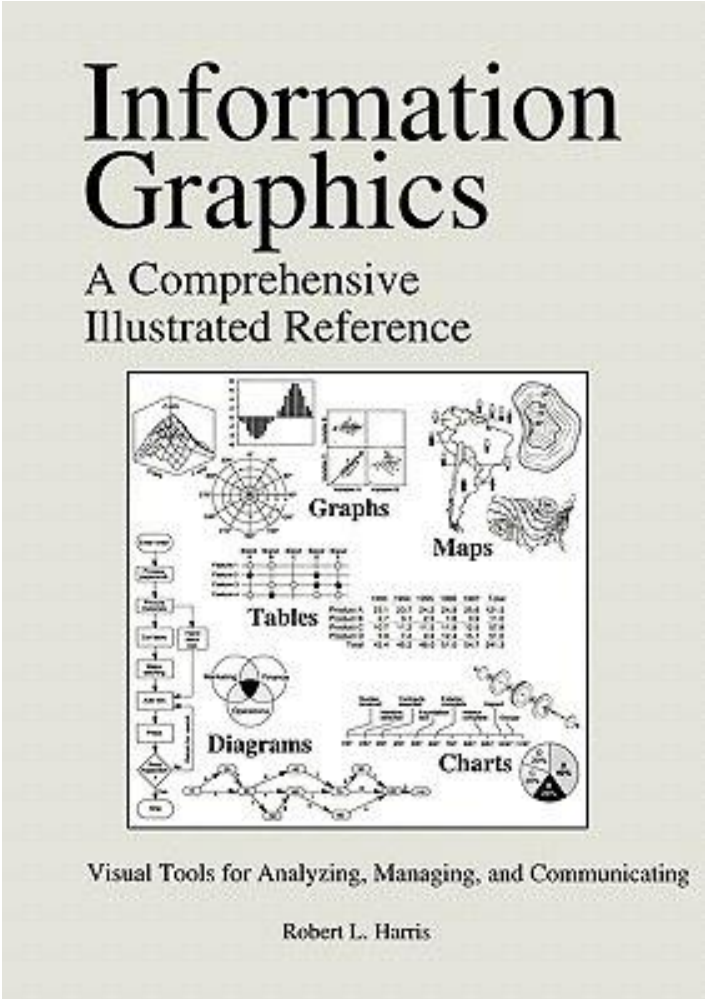
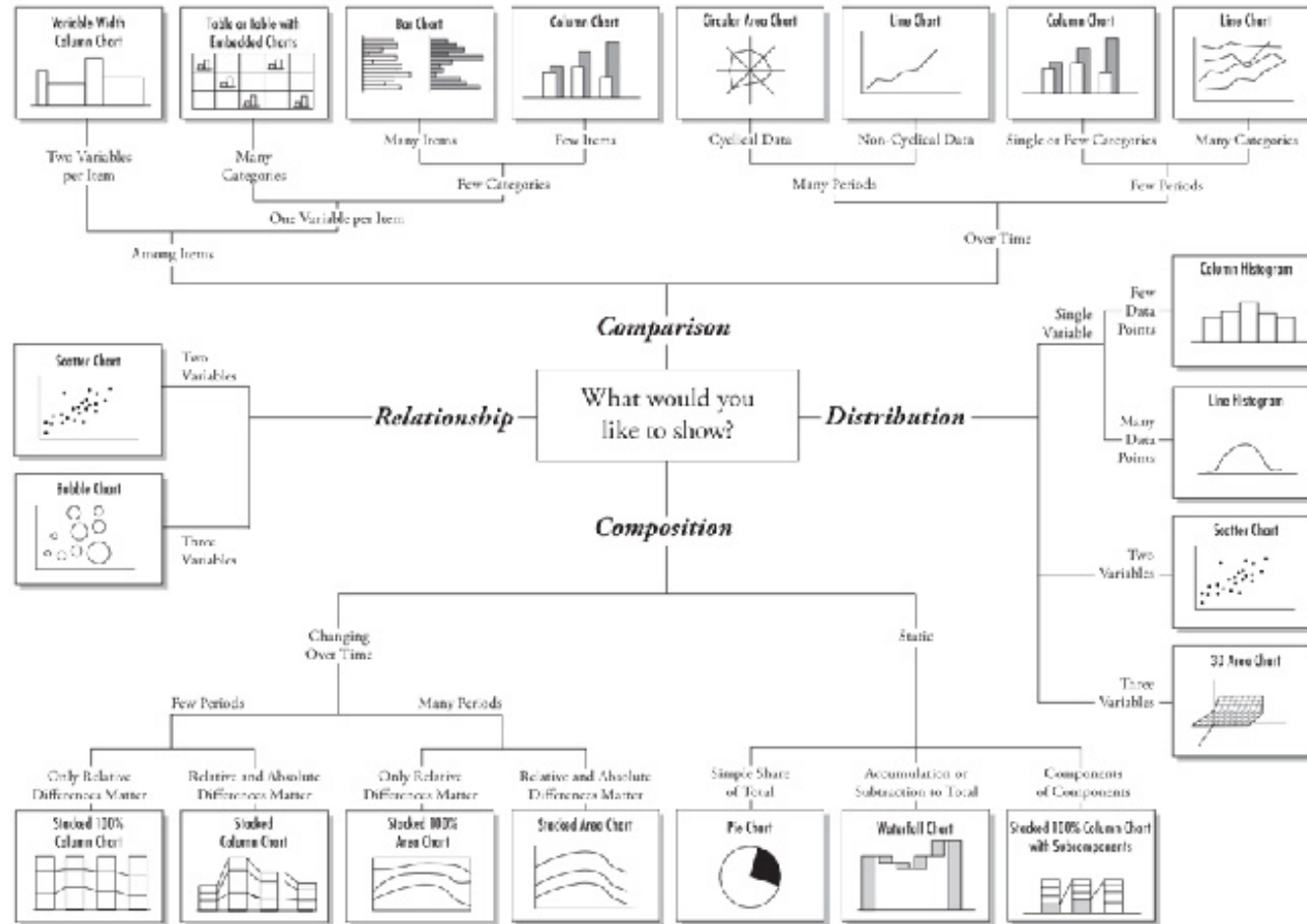

Chart Suggestions—A Thought-Starter



© 2006 A. Abela — a.abela@gmail.com

Bars vs. Lines

Line implies trends. Do not use for categorical data

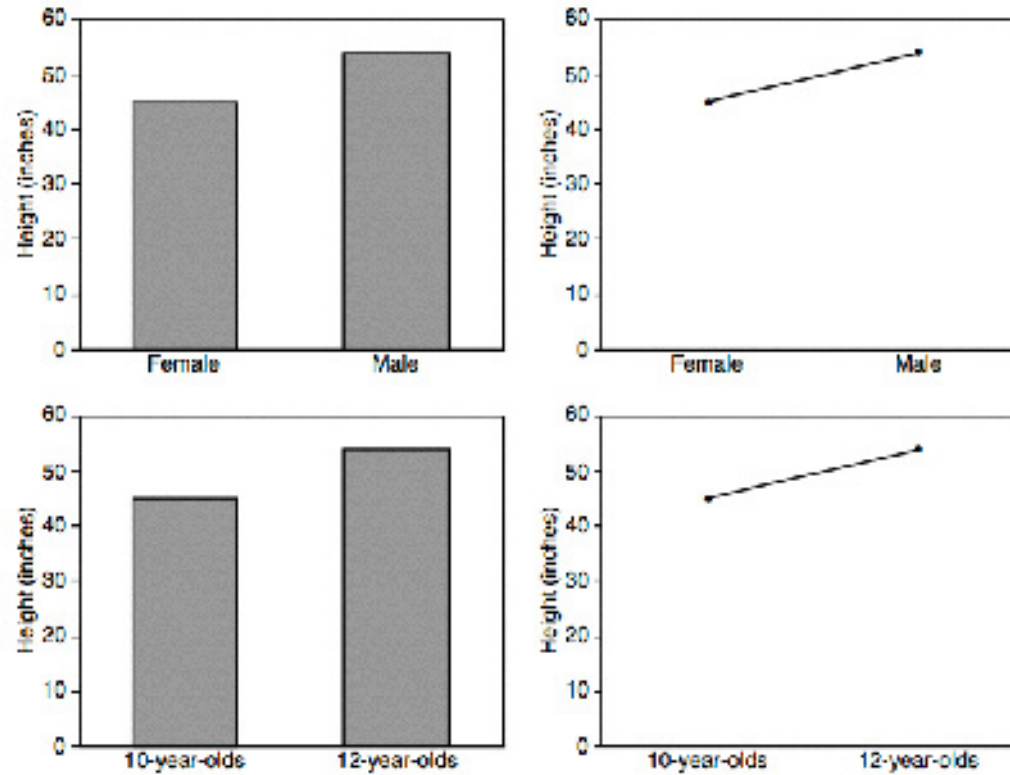

Trend Over Time

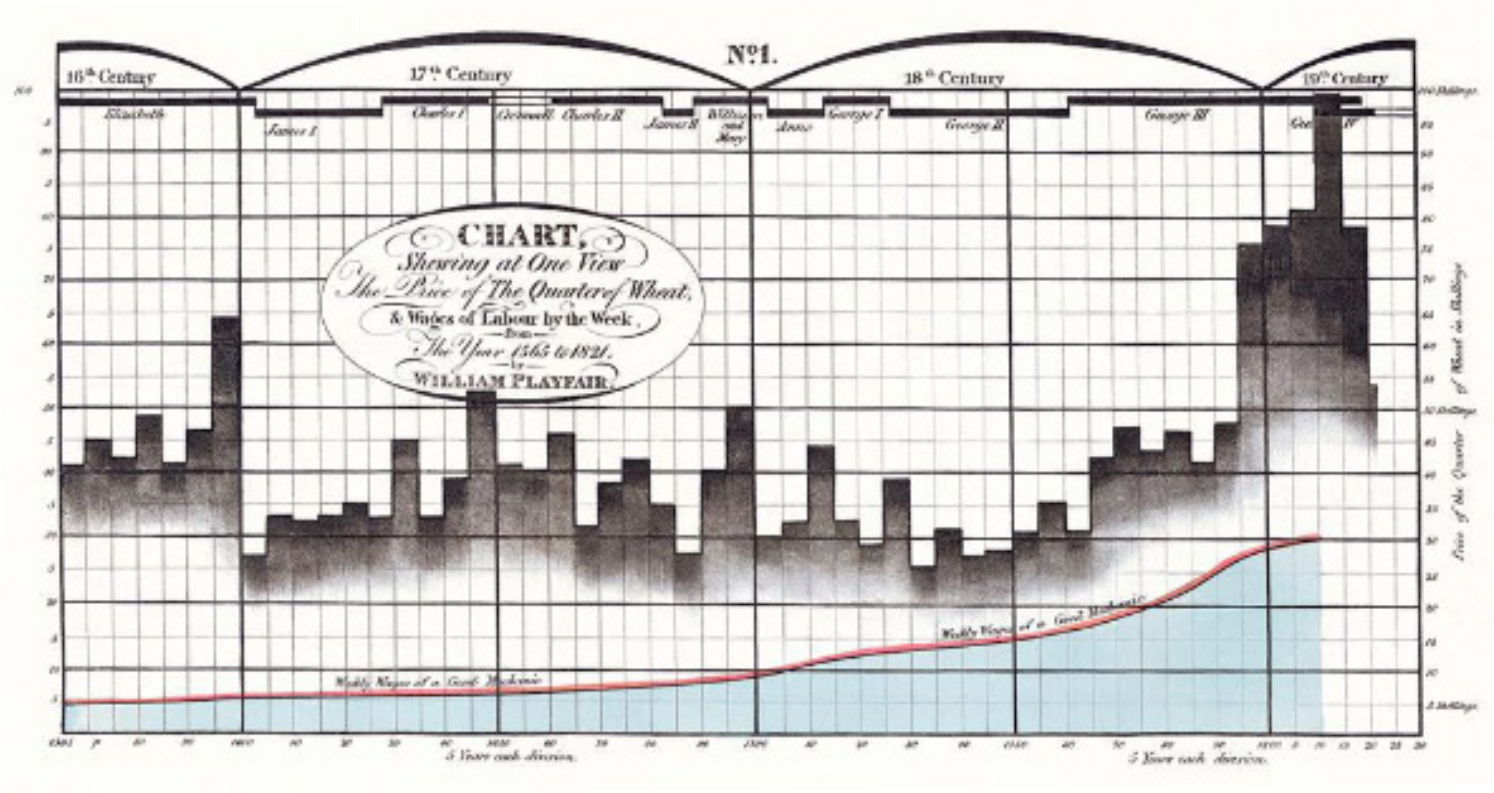

WILLIAM PLAYFAIR 1759-1823

Patterns Over Time

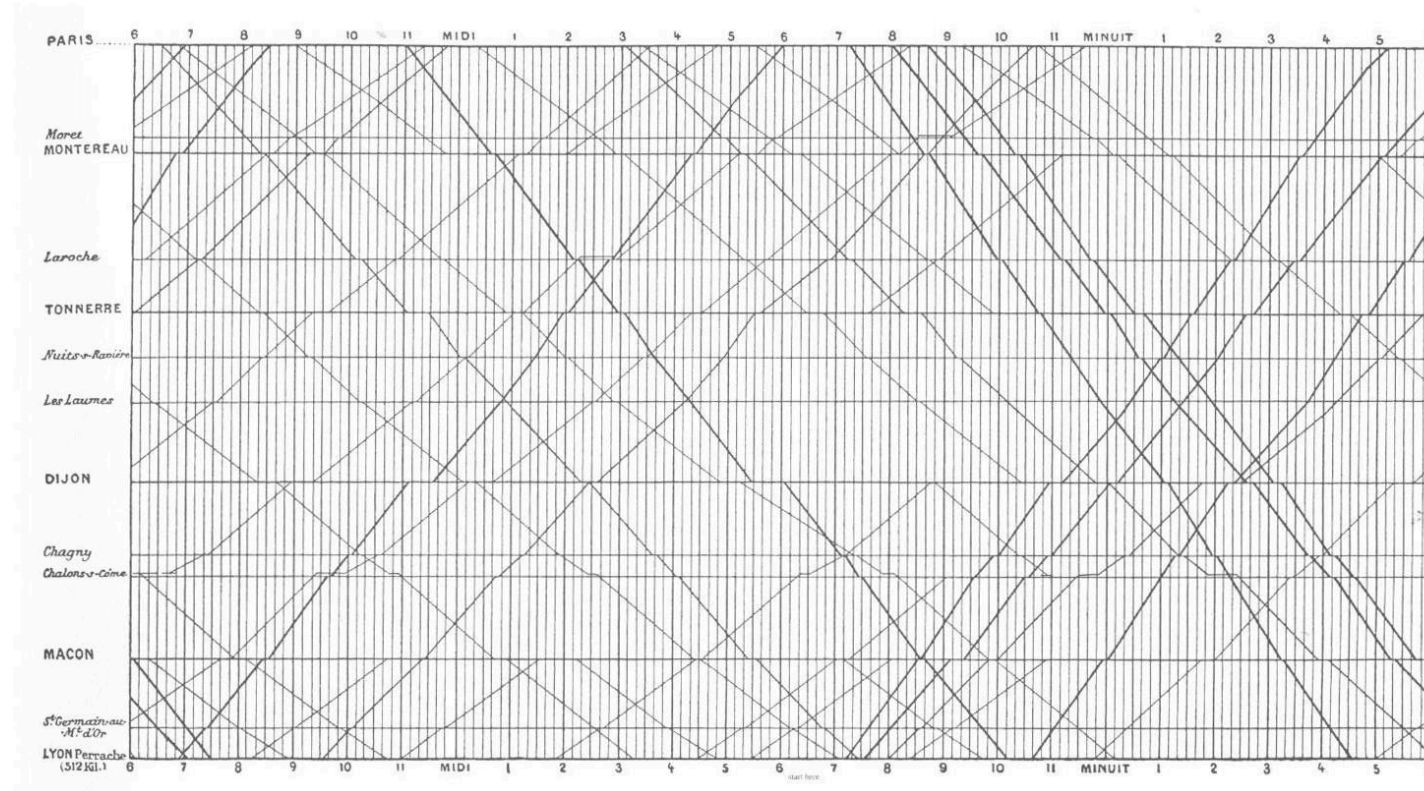

Marey's diagram, 1885

Charting Examples

Sales

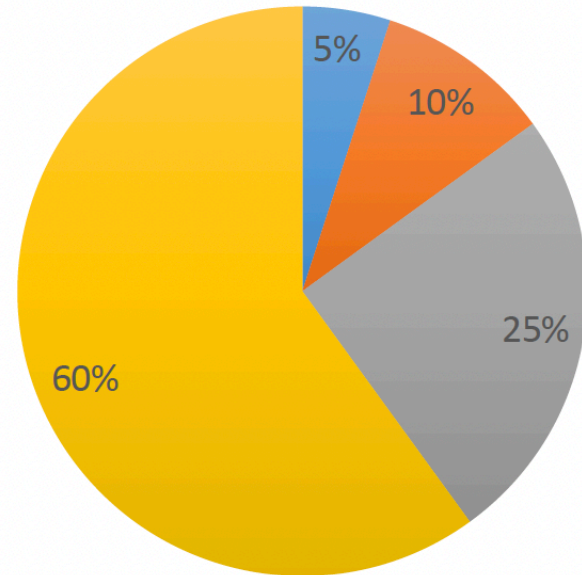

Sales

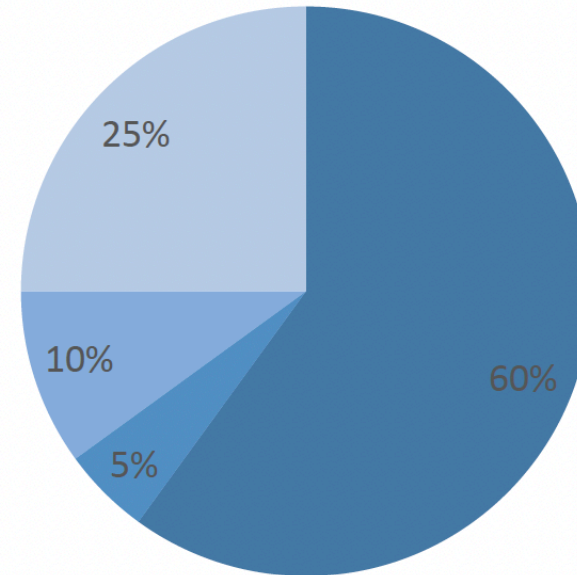

May these charts be improved? Why? How?

Pies vs Bar Charts

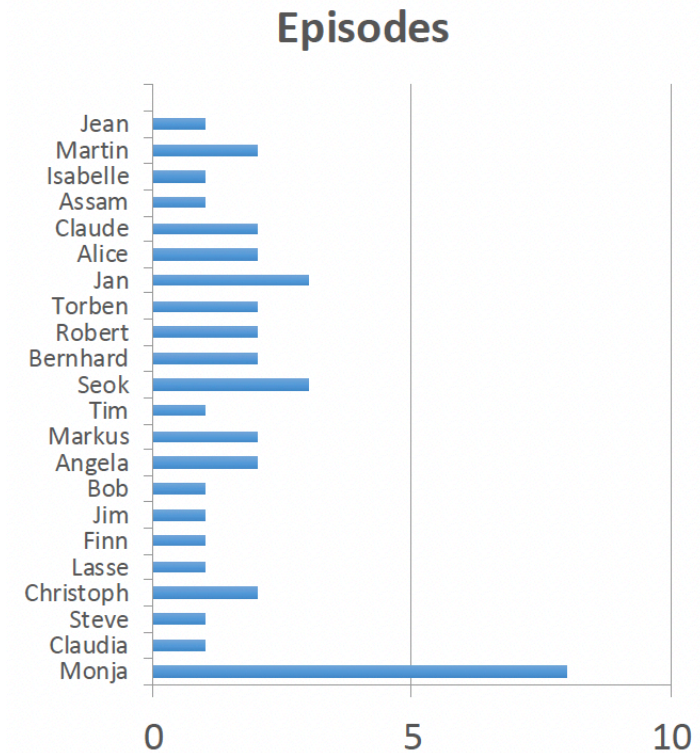
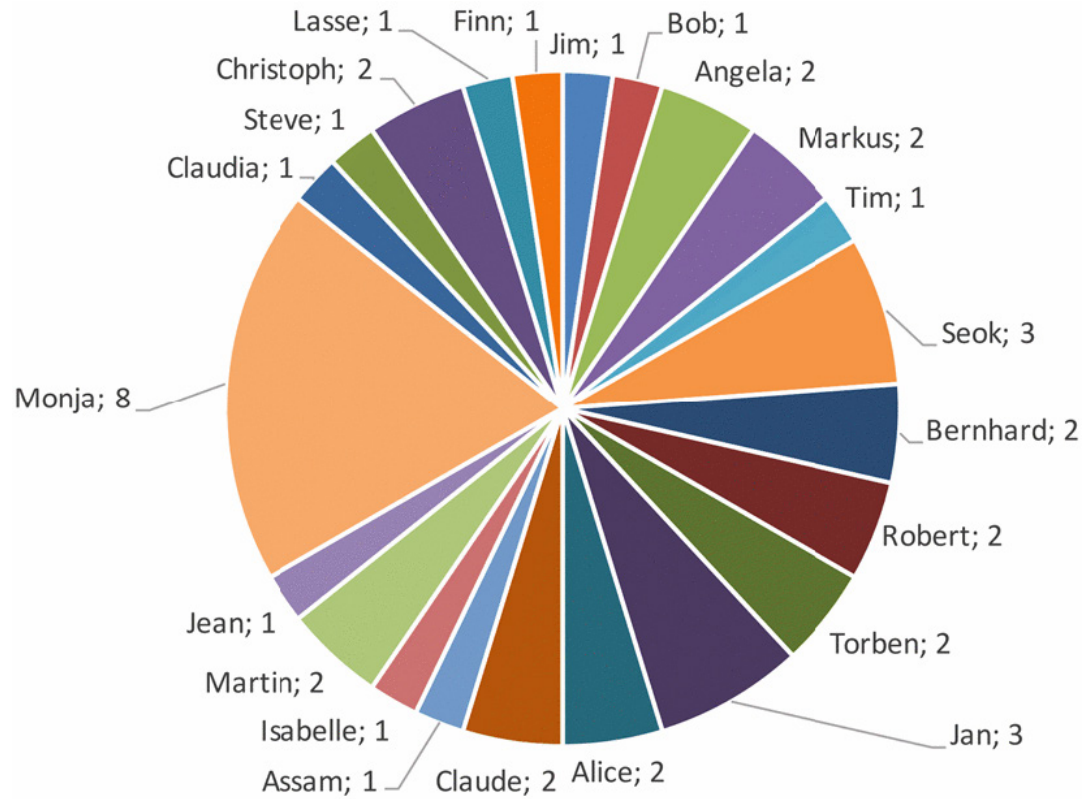

Pies vs Bar Charts (Improved)

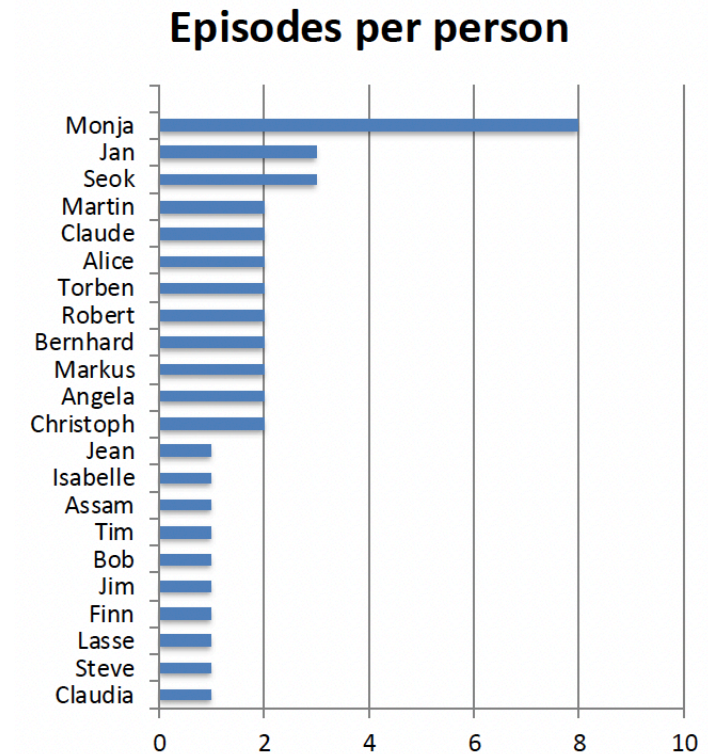
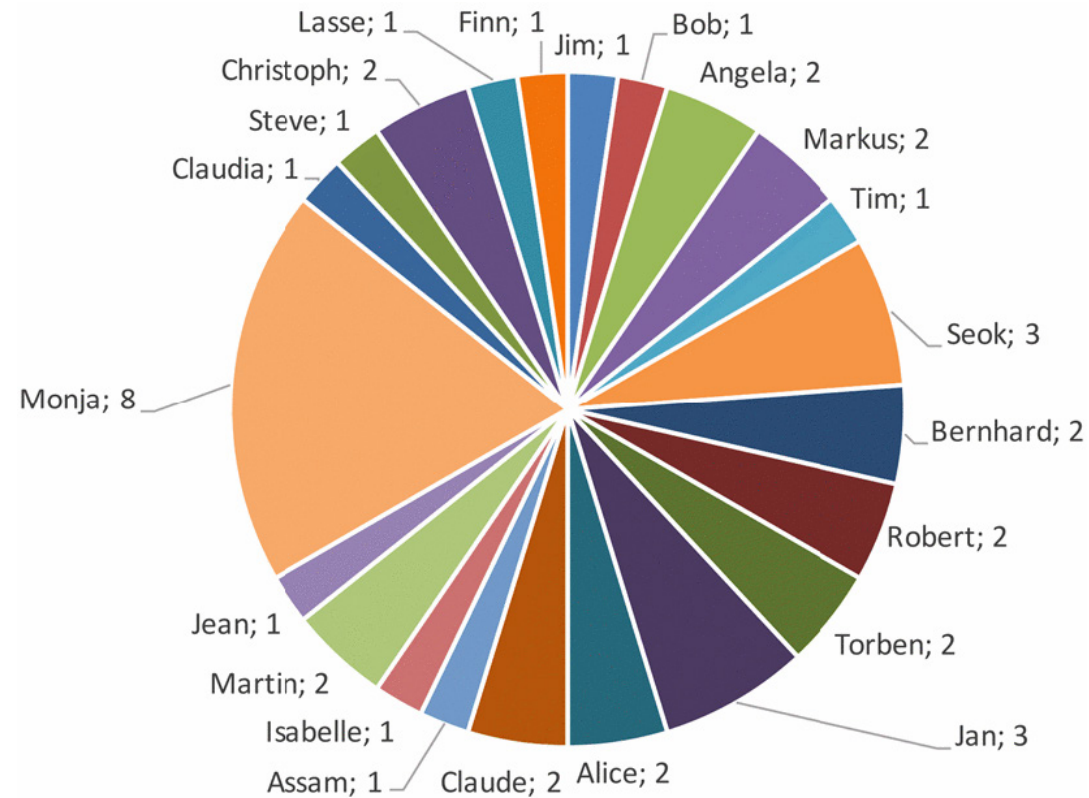

Pies vs Bar Charts (Improved)

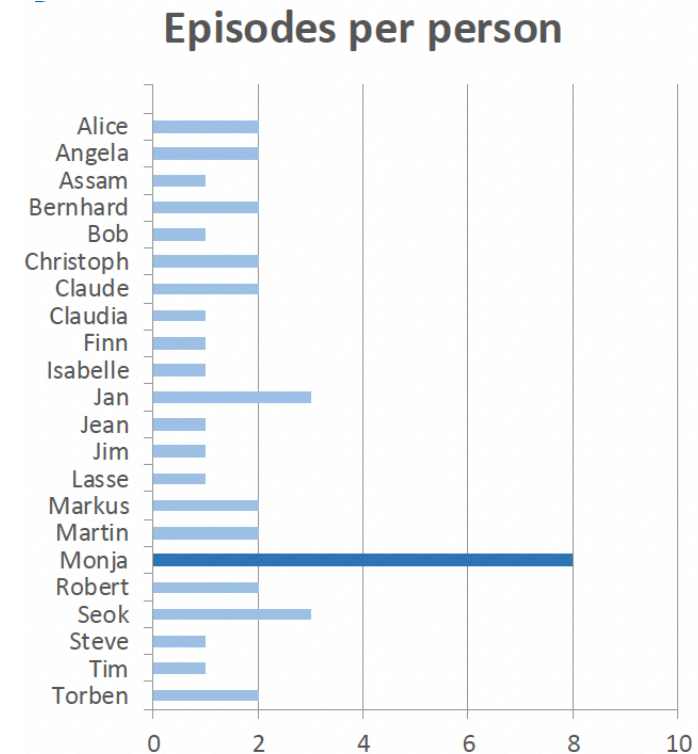
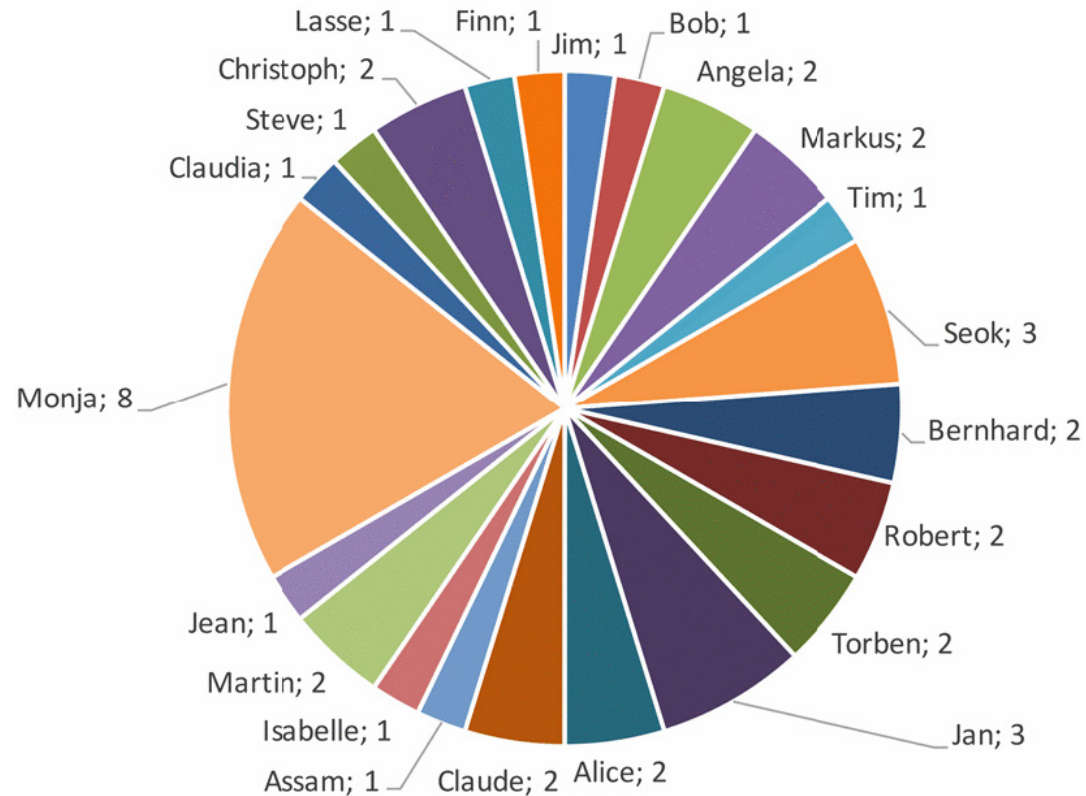

Showing Changes

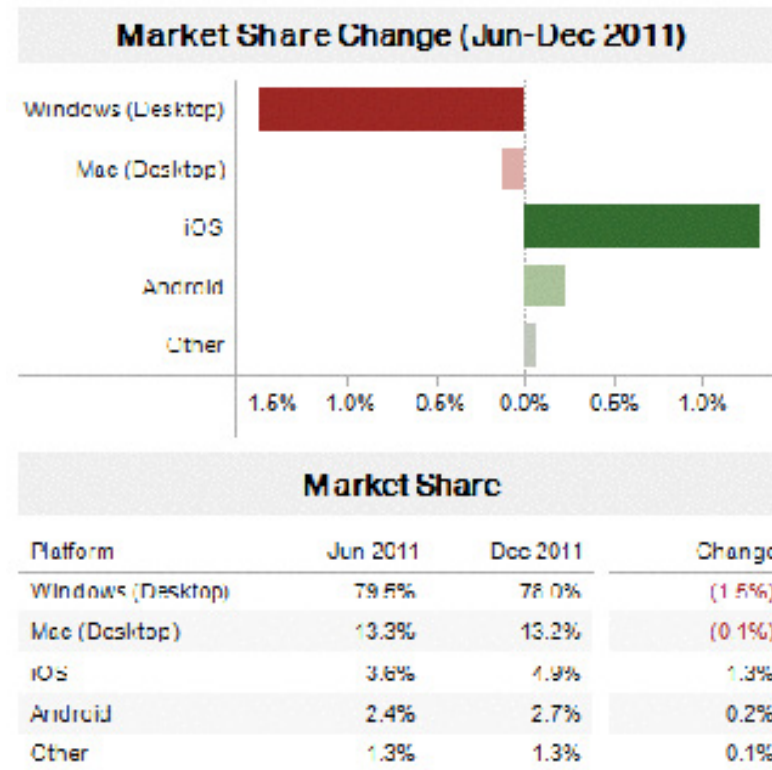
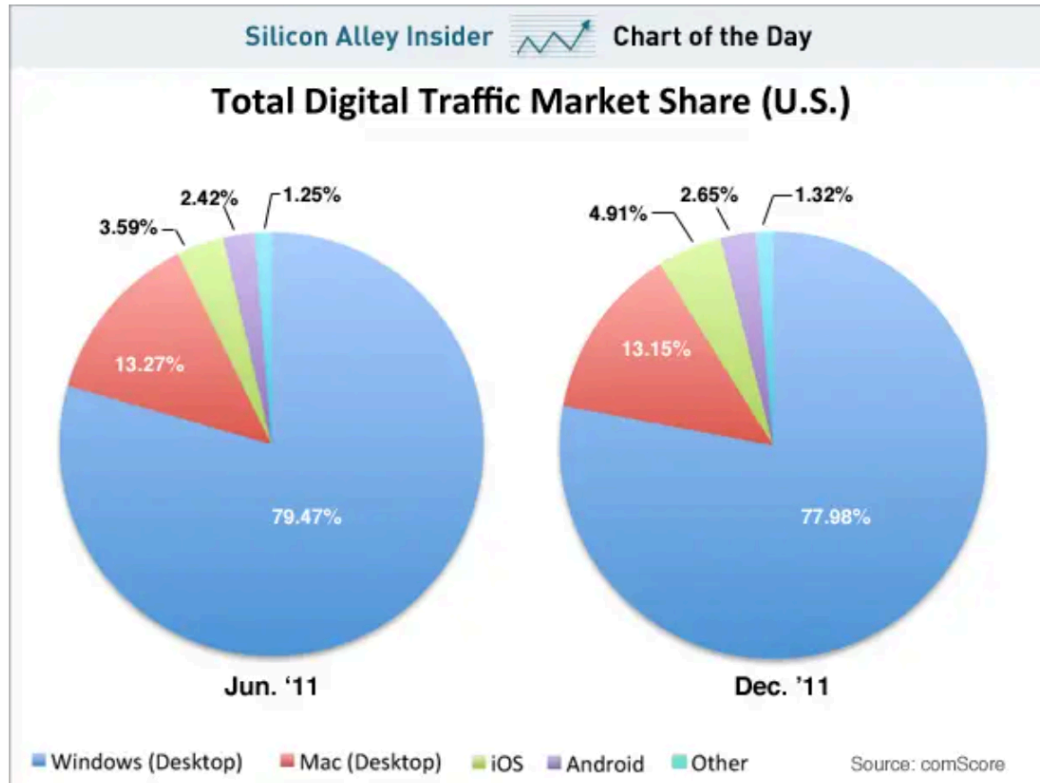

Showing Changes

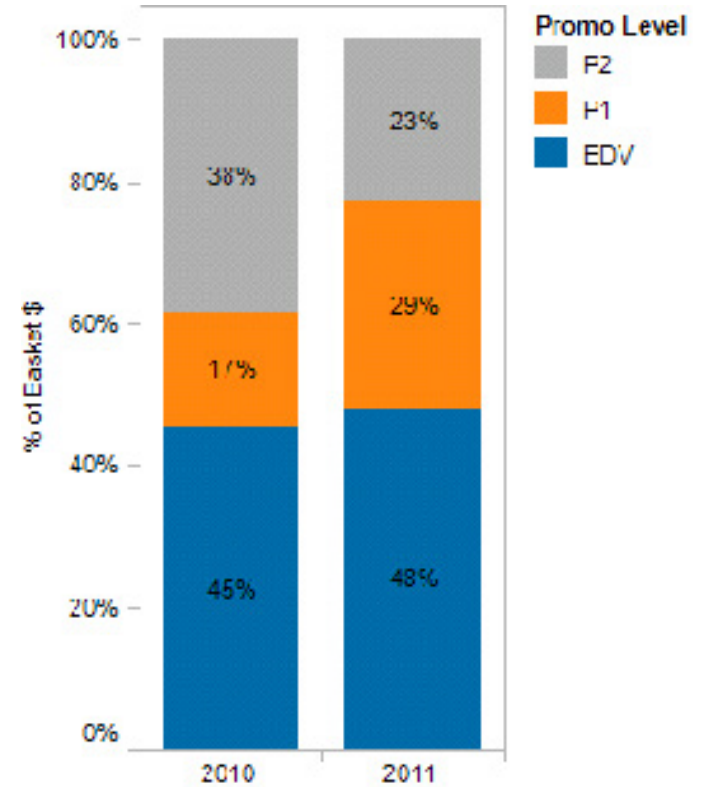
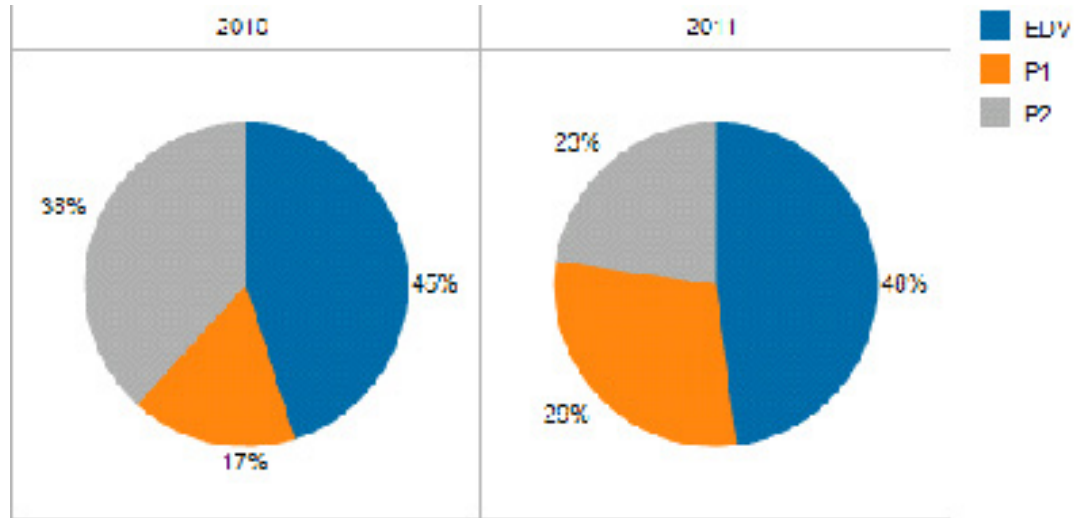

Density Plot

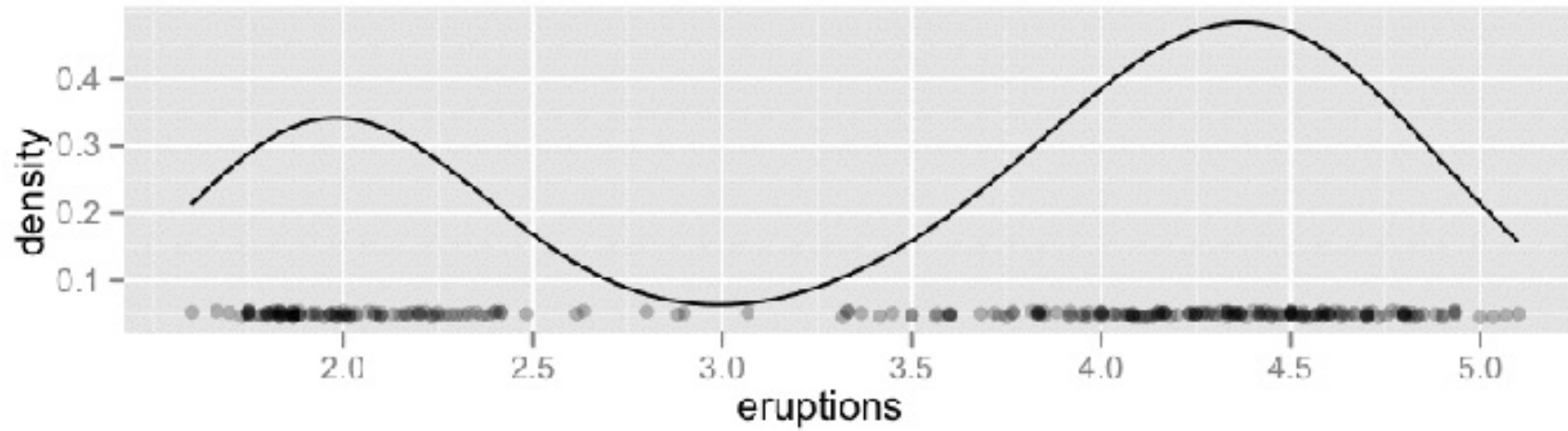

2D Density Plots

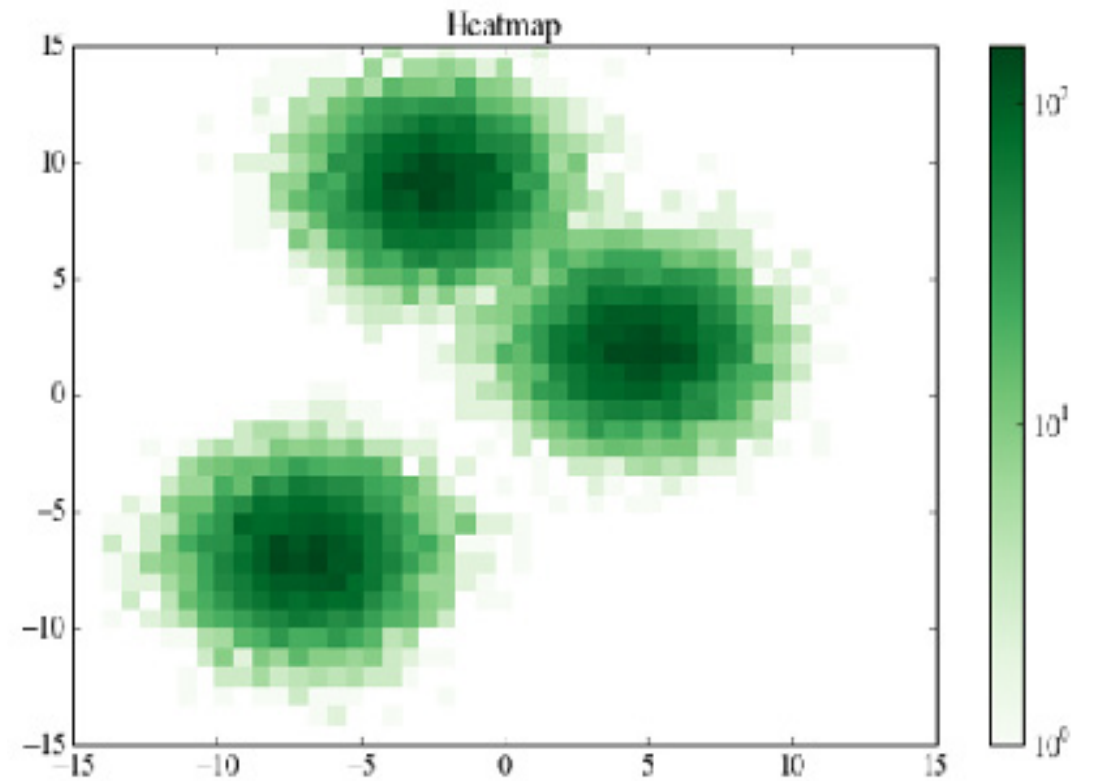
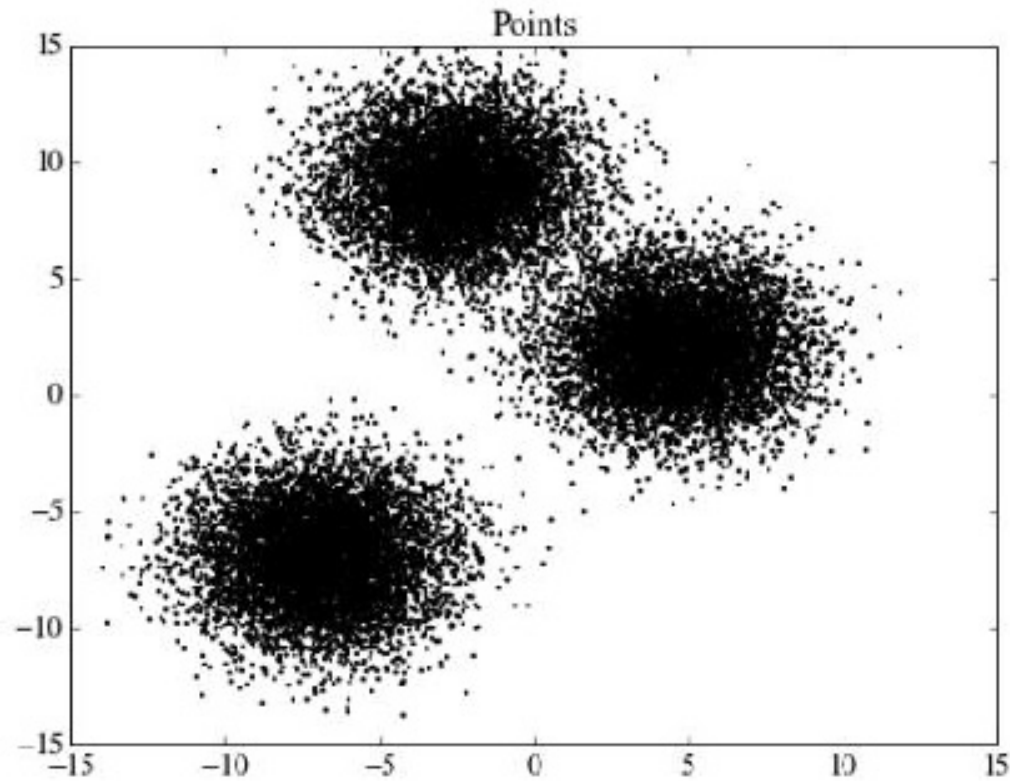

Box Plots

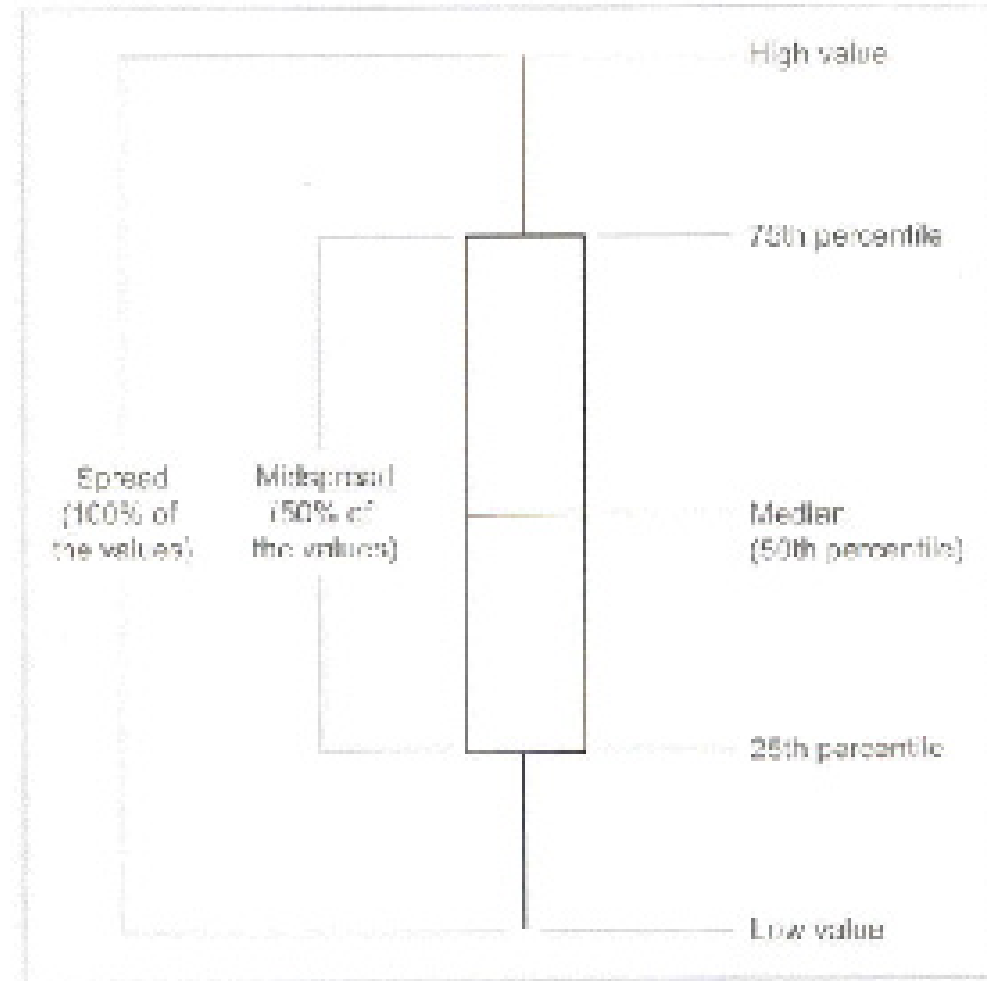

Scatterplot

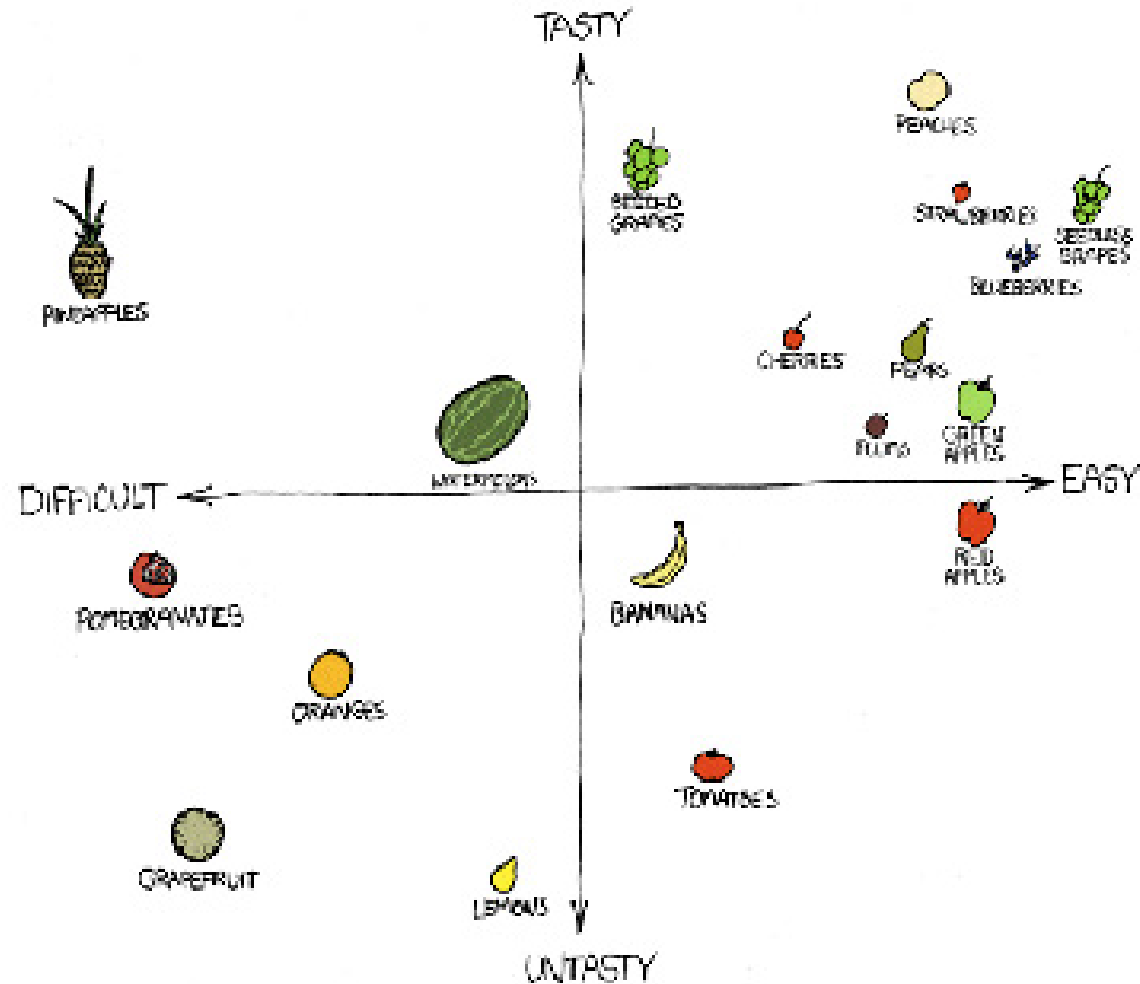

Cluttering, Overplotting

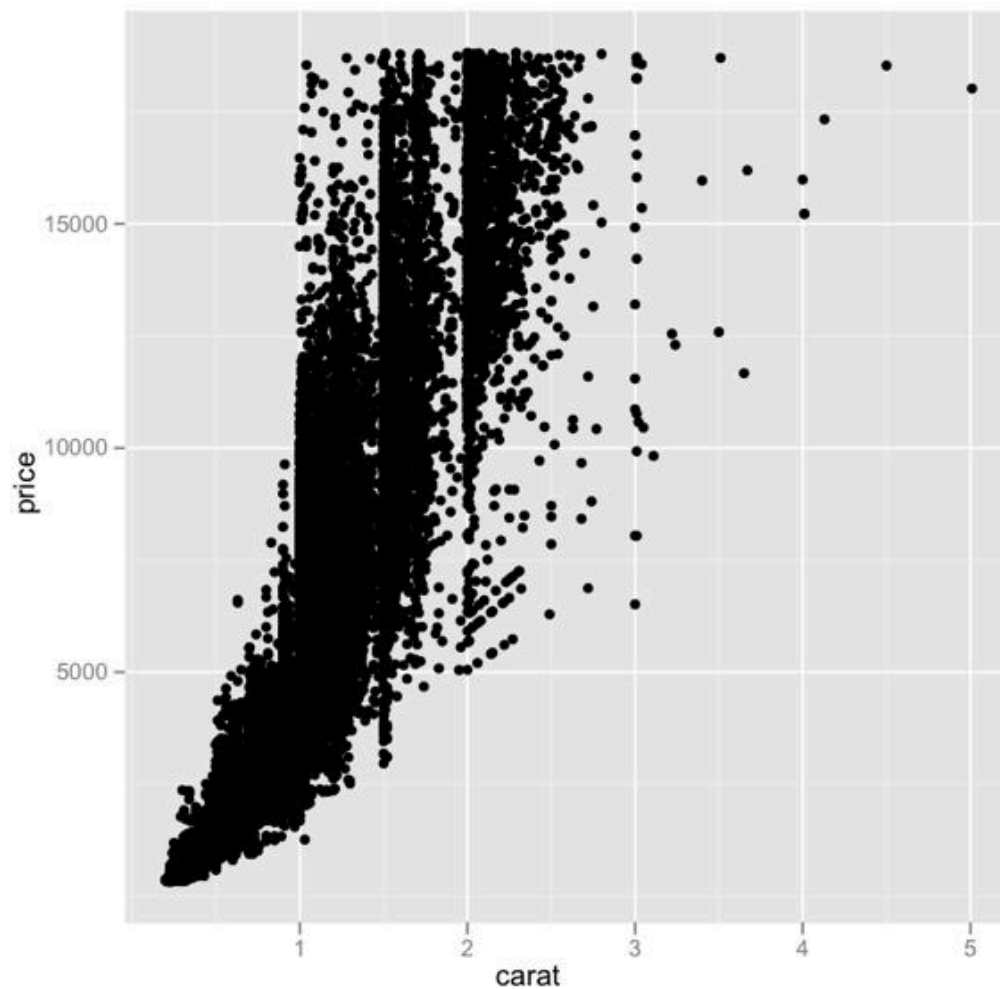

Alpha Transparency Solution

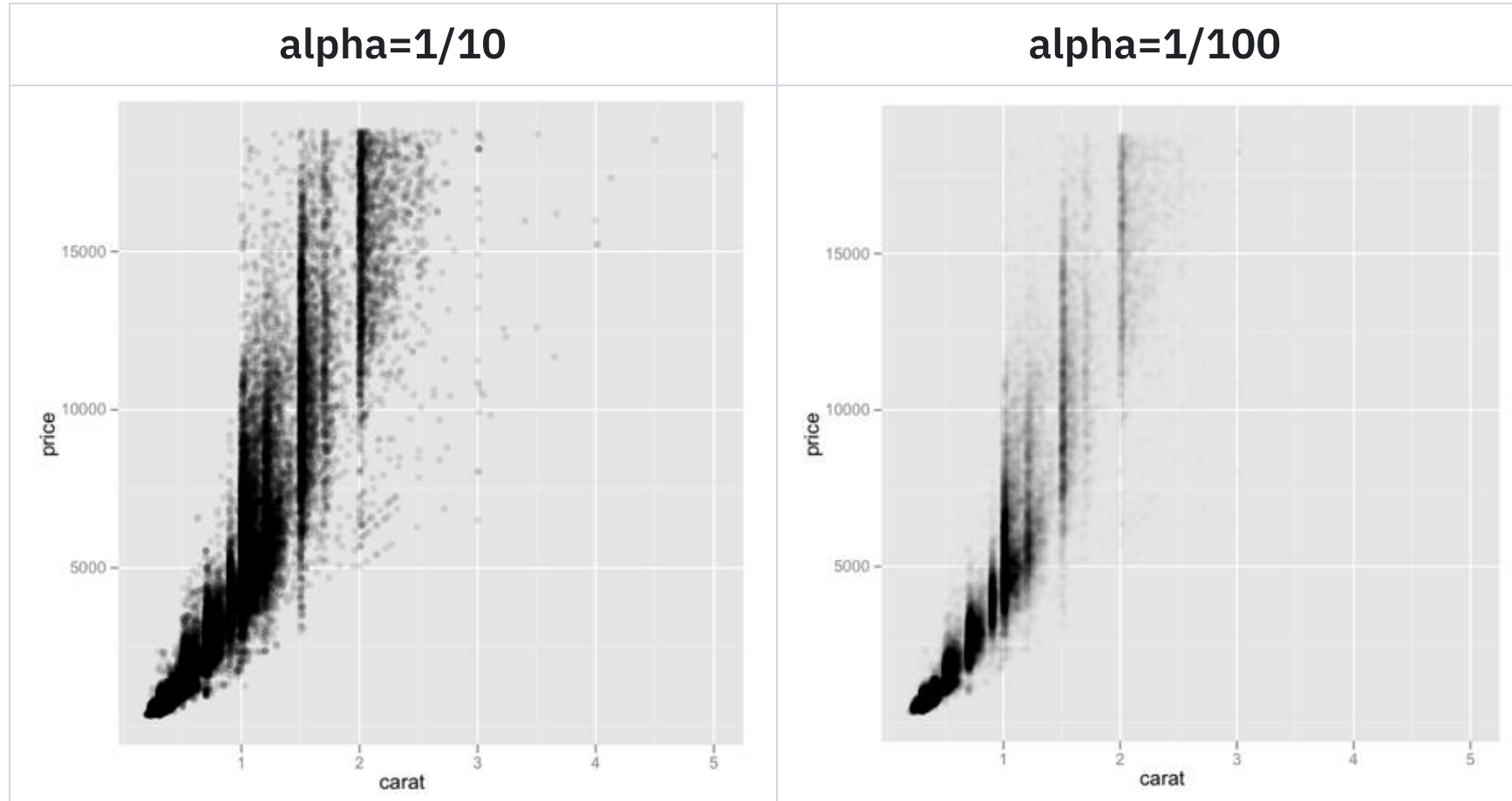

Takeaway Messages

- Charts exploit position on scale as a visual variable
- Best practice to reduce biases and misinterpretation of charts
- Appropriate chart type for specific data type and visualization task

A FEW EXAMPLES AND CASE STUDIES



GDP Growth Example

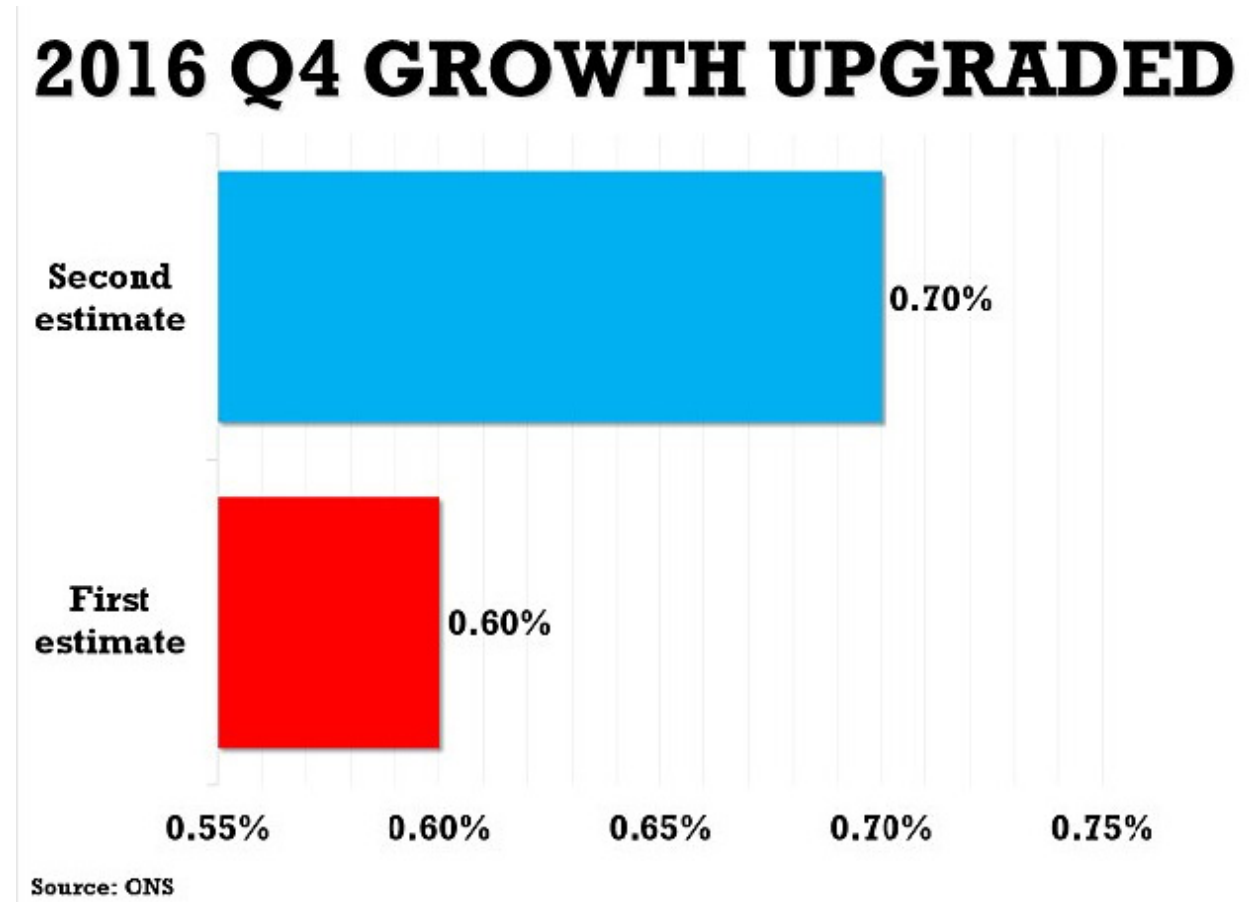

Facebook Analytics Example

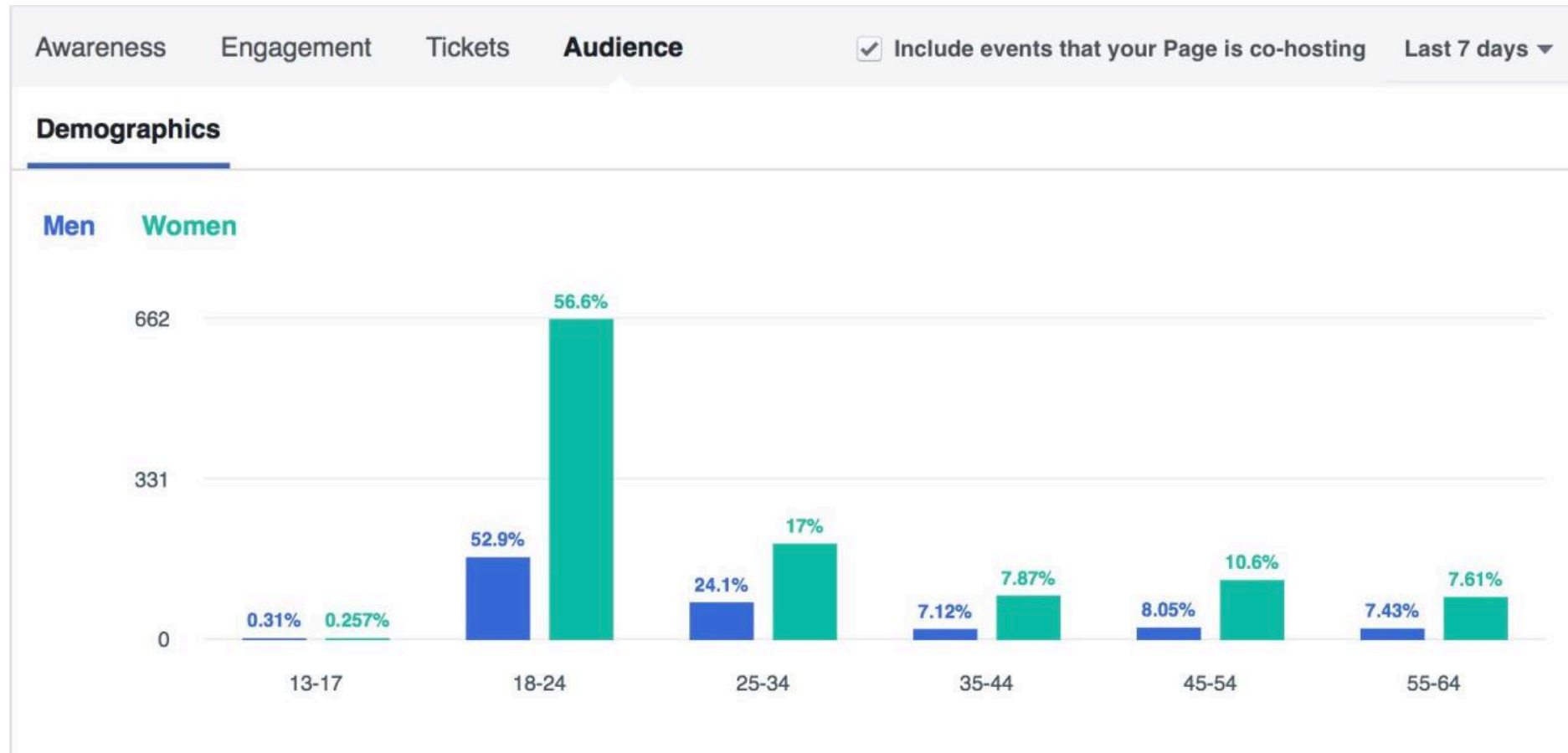

Procent użytków rolnych w gospodarstwach > niż 50 ha:

1989

25%



GAZETA.PL

Photography Industry Example

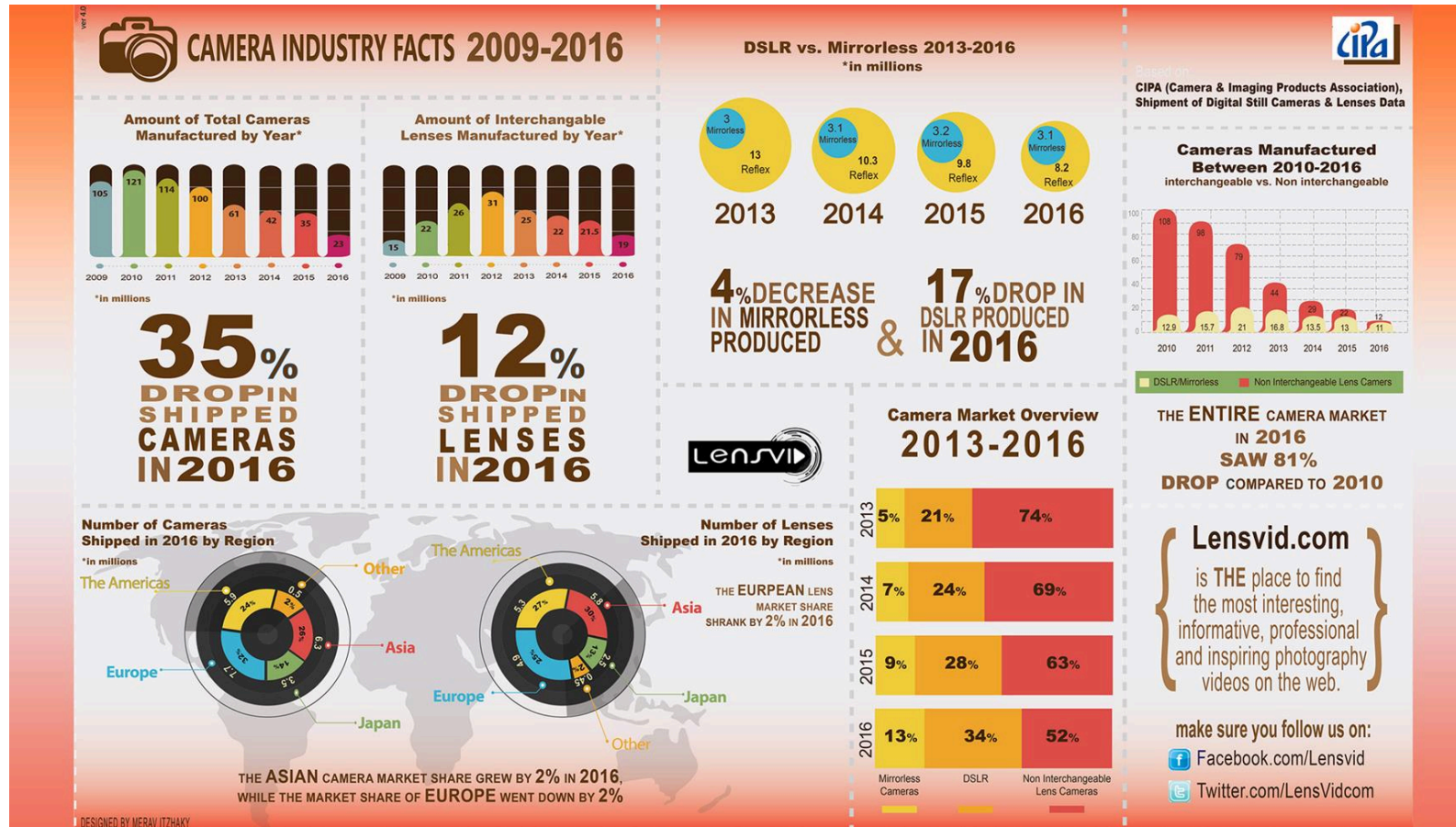

Visual Taxonomy

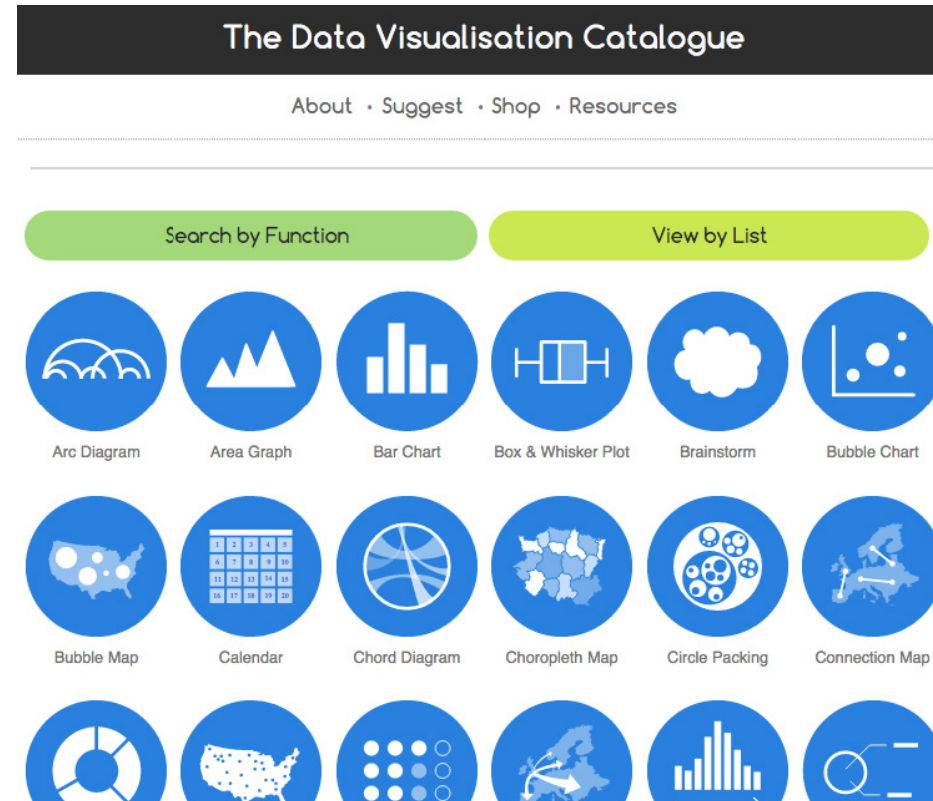

<http://www.datavizcatalogue.com/>